

SONOR®
Drums

Drum Series
Snare Drums
Hardware
Accessories
Cymbals



sonormuseum.de

Mickey Dee (Motorhead)

sonor.com

Excellent engineering & Craftman-ship

made in Germany, since 140 years

The history of SONOR mirrors the excitement of historical and entrepreneurial challenges, in the same way that rhythm is linked to musical creativity and complexity. But throughout all the decades of SONOR history there remains one underlying theme: an uncompromising commitment to quality and dedicated craftsmanship. While the latest technology has found its way into SONOR's production methods over time, the secret of the SONOR sound remains in the meticulous attention to even the smallest detail and the commitment of its founder to always maintain the highest possible level of quality.

Only when sound is becoming a real experience, the SONOR quality standard is met. From precision craftsmanship musical expression is shaped.

Welcome to the exciting world of SONOR Drums! Have fun browsing through this catalog and learn more about the SONOR history and the wide array of Drums, Hardware, Cymbals and Accessories.

Your SONOR Drum team

www.sonor.com



www.youtube.com/SonorDrumTube



www.facebook.com/sonordrums



www.twitter.com/sonor_drums

© SONOR GmbH & Co. KG | Catalog DR 01012015 E
Product Design: Thomas Barth, Karl-Heinz Menzel, Philipp Rabe, Werner Saßmannshausen, Michael Stumm, David Schulz
Product Photography: Martin Kreutter, Marburg, Shansi, Beijing and SONOR, Bad Berleburg-Aue
Cover Photo: Ray Ahner
Concept and Graphic Design: Krause & Krause, Marburg
Text Concept: Thomas Barth, Michael Stumm, David Schulz, Gary Ingrassia, Scott Atkins
SONOR reserves the right to update or change its products without advance notice. Wood is a natural product, which can cause slight alterations in color and grain.
Print reproduction of Drum designs and finishes can vary depending on color density and general print quality.

Rich Thair (Red Snapper / Molokko) Picture by Grzegorz Lepiaz



SONOR History 02

Drum Series

Vintage Series 04
ProLiteSeries 14
Ascent Series 30
Select Force Series 32
Essential Force Series 34
Smart Force / Smart Force Xtend Series 36

Special Edition Sets

Martini / Bop / Safari / Players 38

Snare Drums

Artist Series 42
Gavin Harrison 'Protean' Signature Snare Drum 44
Benny Greb Signature Snare Drum 44
Mikkey Dee Signature Snare Drum 45
Phil Rudd Signature Snare Drum 46
Steve Smith Signature Snare Drum 46
Phonic Snare Drums 47

Hardware

Perfect Balance Bass Drum Pedal 50
Giant Step Bass Drum Pedal 52
600er Bass Drum Pedal 53
400er Bass Drum Pedal 53
HiHats 54
Drum Thrones 55
Cymbal Stands / Double Cymbal Stands / Cymbal Boom Arms 56
Snare Stands / Combination Stands / Tom Stands 58
Basic Arm System 60
Tom Holder / X-Hats / Multi Holder 62
Hardware Sets / Multi Clamps 63

Accessories / Soundwires 64
Bags / Drumheads / Drumsticks 65

Armoni Cymbals

Armoni Cymbal Sets and Series 66



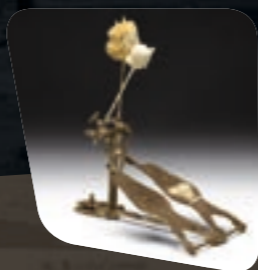

Horst Link



SONOR



1875 - 1900

In 1875 Johannes Link, a trained wood turner and tanner, started a small workshop for simple military drums and drum heads in Weißenfels an der Saale in East Germany. From these modest beginnings developed a flourishing business, which at the turn of the century already offered a comprehensive range of percussion instruments.



Johannes Link

1900 - 1925

In 1900, SONOR introduced its first single bass drum pedal. A simple mechanism built under simple circumstances, still far from what was introduced over a century later under the name „Giant Step“ or „Perfect Balance“. In 1907 the SONOR trademark was registered with the Imperial Patent Office. In 1914 Otto Link, son of Johannes Link, assumed management of the company after the passing of the founding father. Around 1925, celebrating its 50th anniversary, SONOR had 145 employees and was one of the largest businesses of its kind.

Otto Link later became Consul to Sweden and a personal friend of King Gustav V. Due to this connection, the Link Company became the exclusive supplier to the Swedish royal house. This relationship was the base for SONOR's rebirth in Aue after WWII.



Otto Link

1925 - 1946

More innovations were being introduced, such as the first double pedal „Duplex“ in 1927. The first Snare Drum with multi 3-way strainer, a novelty for its time, was introduced to the market in 1930. Military contracts kept the company busy during the war time, but the emerging war results in the collapse of the golden Weißenfels era.



1946 - 1960

At the close of World War II, Otto Link's son Horst returned from military service to begin work at the family business. However, when the Russian occupation forces in East Germany began arresting the returning German soldiers and sending them to Siberia, Horst fled to Aue, in the British-occupied section of Germany. There, he established a tannery in a rundown army barracks and began making drum heads. Starting a drum company in Aue was no small feat. The area was largely populated by dairy farmers, who were unskilled for his company's needs. Reflecting on this period, Horst Link said, „The lack of skilled labor initially made our job very difficult. We had to train everyone from scratch. But over the years, having located in Aue has helped us immeasurably. We have a stable and loyal work force that we could never duplicate in a larger city.“

In 1952, the first drum kit with concert toms was introduced. At the same time, SONOR introduced the famous „script logo“ trademark which embellished all drums from the early teardrop era for nearly a decade.



1960 - 1990

In 1961, the first SONOR „Mallet“ logo was introduced, created by famous designer Otl Aicher. The Mallets have been an inherent part of the design not only of the logo trademark, but also in product design until today. The following decades marked a striking number of milestones in the company's ongoing journey of innovation and craftsmanship. 1973 saw the introduction of Vertical Grain Drums on the „Champion“ Series. In 1975 the famous Phonic Series as well as Champion Acrylic drum sets were introduced. In the same year, the 45 degree bearing edge was introduced and used on all series from then on. More notable series from this era, and highly sought-after collector's items are Signature (1982), Phonic Plus (1983), Lite (1984) and HiLite (1986). In 1993 the Jet Set (based on the Signature Series), with 24k gold plated hardware, being the most expensive drums for its time, creates international buzz. SONOR continues to modernize and yet like Henry Ford 60 years earlier, makes most components in-house. Raw materials come in, finished products go out. This tradition continues into the early 1990's.



1994 - today

Taking drum manufacturing to the next level: the era of customization is kicked off. The Designer Series, introduced in 1994, is the first series that offers multiple choices of shell construction, drum sizes, finishes, and hardware. The idea was taken to a new level and perfected with the launch of SQ² drums in 2006. One kit build at one time, no one like the other, each drum a masterpiece of handcraftsmanship and as unique as a fingerprint.

In 2000, SONOR introduced the Delite series which set the stage for its successor, the ProLite Series (2012). Like in all other decades, remarkable technical innovations in the hardware sector go hand in hand with some of the finest drums available: Giant Step pedals in 2001, and Perfect Balance Pedal designed by Jojo Mayer in 2012.

And today? We are looking back at a history like no other in the industry of drum manufacturing. We literally hit the reset button and (re-)introduce the analogue sound into a digital world: the Vintage Series. Taking the best from the past in combination with our experience in modern manufacturing technology „Made in Germany“.





Vintage Series

Vintage Set in Vintage Pearl (17329)

Setup: Bass Drum 24" x 14" / Tom Tom 13" x 8" / Floor Tom 16" x 14" /
Floor Tom 18" x 16" / Snare Drum 14" x 6.5"

Hardware: Single Tom Stand (STS 676 MC) / Snare Drum Stand (SS 677 MC) /
Hi-Hat Stand (HH 674 MC) / Mini Boom Stand (3x) (MBS 673 MC) /
Bass Drum Single Pedal (PB Perfect Balance)



the
analog sound
in a digital world

The new SONOR Vintage Series, Made in Germany

With the 140th Anniversary of the company, SONOR brings back an iconic sound and look of the time in between the 1950's and the early 1970's and proudly reveals the Vintage drum series, Made in Germany. Already in the 1960's SONOR Teardrop kits were build to highest quality standards, highly rated by international stars like Connie Kay, Sonny Payne or Kenny, Klook' Clarke.



SONOR kit from 1962*

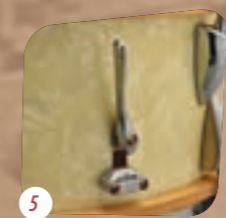
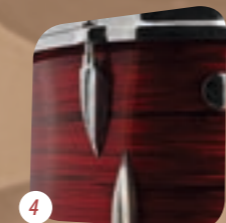
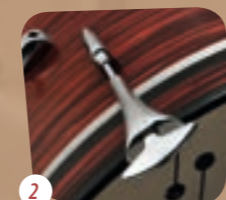

*Above pictures show items and colors that are no longer available from SONOR

SONOR Teardrop kits are one of the most sought after vintage drums. Utilizing rounded bearing edges, the new Vintage series drums represent the return of the 'old SONOR sound' into its product line. SONOR introduced the 45 degree bearing edge in 1975, which we still use today on all SQ2, Prolite, and Force series drums. With the addition of the Vintage Series, drummers will have access to a complete palette of sounds that is uniquely SONOR.

The SONOR team, in cooperation with artists and collectors, worked tirelessly to bring the new Vintage drum line as close as possible to the look, feel and sound of its predecessor the Teardrop drums. SONOR then combined its knowledge of modern drum building, with the look and sound of vintage drums, to create an instrument that will hold up to today's modern playing.

SONOR catalogue page of the 50's



Like in the original Teardrop drums, the Vintage drum series feature hand-selected premium German Beech shells with rounded bearing edges. We have carefully recreated the look and feel of the 1950's teardrop lug and updated it with SONOR's exclusive TuneSafe™ system. Being sure not to overlook any details, SONOR

has redesigned the Superprofil triple flanged hoops and brought back the timeless SONOR badge and logo used in between 1952 and 1961.

Vintage snare drums feature a new throw off. The 'Super 50', a completely redesigned strainer, was inspired by the throw off which was used on the SONOR D-411 and D-412 snares in the 1950's.

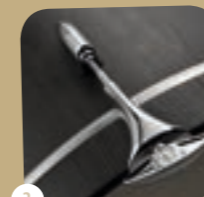

1) Original logo and new Vintage series logo 2) Original and new claw / tension rod design 3) Original Superprofil hoops from the 50's and redesigned new Superprofil version 4) Original and new Teardrop lugs 5) Original strainer design and redesigned Super 50 throw off (outside and inside mechanism)



Vintage Three 20 Shell Set in Vintage Onyx (17306)

Setup: Bass Drum 20" x 14" / Tom Tom 12" x 8" / Floor Tom 14" x 14" additionally shown: Snare Drum 14" x 5.75"

Hardware: Single Tom Stand (STS 676 MC) / Snare Drum Stand (SS 677 MC) / Hi-Hat Stand (HH 674 MC) / Mini Boom Stand (3x) (MBS 673 MC) / Bass Drum Single Pedal (PB Perfect Balance)





Rebirth

Bringing back the „old SONOR sound“ with rounded bearing edges. The result is a warm, dry but yet resonant sound. Shell Construction: 9 ply Beech shells with 6 mm shell thickness featuring SONOR's unique CLTF and OSM process.



TuneSafe - Right in Tune, 100% of the Time!

All SONOR lugs are equipped with the patented TuneSafe, which prevents the tension rods from loosening.

Vintage Reference

Vintage Bass Drums

Bass Drum	18" x 14"	VT 15 1814 BD NM
Bass Drum	20" x 14"	VT 15 2014 BD NM
Bass Drum	22" x 14"	VT 15 2214 BD NM
Bass Drum	24" x 14"	VT 15 2414 BD NM

NM = No Mount

Vintage Snare Drums

Snare Drum	14" x 5.75"	VT 15 14 x 5.75 SDW
Snare Drum	14" x 6.5"	VT 15 1465 SDW

Vintage Tom Toms

Tom Tom	10" x 8"	VT 15 1008 TT
Tom Tom	12" x 8"	VT 15 1208 TT
Tom Tom	13" x 8"	VT 15 1308 TT

Vintage Floor Toms

Floor Tom	14" x 12"	VT 15 1412 FT
Floor Tom	16" x 14"	VT 15 1614 FT
Floor Tom	18" x 16"	VT 15 1816 FT

Vintage Preconfigured Shell Sets

Vintage Three 20 Shell Set	BD 2014 NM, TT 1208, FT 1412
Vintage Three 22 Shell Set	BD 2214 NM, TT 1308, FT 1614

NM = No Mount



Vintage Three 22 Shell Set in Vintage Natural (17321)

Setup: Bass Drum 22" x 14" / Tom Tom 13" x 8" / Floor Tom 16" x 14"

Additionally shown: Snare Drum 14" x 6.5"

Hardware: Single Tom Stand (STS 676 MC) / Snare Drum Stand (SS 677 MC) / Hi-Hat Stand (HH 674 MC) / Mini Boom Stand (3x) (MBS 673 MC) / Bass Drum Single Pedal (PB Perfect Balance) / Drummer's Throne round seat (DT 6000 RT)



Recommended

Wanna play just like back in the „Vintage“ days? Try our 2000 Lightweight Series!



Vintage Series



Original image of 1955 SONOR catalogue

Did you know?

The „Superprofil“ hoop is an authentic remake of the hoop used on all Tom Toms, Floor Toms and Snare Drums built by SONOR until the 1970s.



Drumheads Made by REMO® USA

Tom Toms / Floor Toms: Ambassador White Coated, Ambassador Clear
Snare Drums: Ambassador White Coated, Ambassador Resonant
Bass Drums: Powerstroke3 White Coated for 18" and 20" / Powerstroke3 White Coated Black Dot for 22" and 24", Fiberskyn Powerstroke3 with black SONOR Vintage logo

Vintage inside and outside

The semi gloss lacquered „Vintage Onyx“ and „Vintage Natural“, plus the stylish aged „Vintage Pearl“ wrap finish relate perfectly to the Teardrop era.



Vintage Onyx
Stain Satin Gloss (17306)

Vintage Natural
Stain Satin Gloss (17321)

Vintage Pearl
Wrap (17329)

Vintage Three 22 Shell Set in Vintage Natural
(additional items shown)

Vintage Three 20 Shell Set in Vintage Onyx
(additional items shown)

Vintage Set in Vintage Pearl

Did you know?

SONOR slotted tension rods are being offered as an option for those devoted to the SONOR „speciality“ and seeking to replace the square head tension rods on their Vintage series kits!

(item no. 190 343 01, 56 mm length, fits Tom Toms, Floor Toms and Snare Drums, pack of 6pcs.)

SONOR Museum.de

let's talk SOUND

During the last several decades, Music has continued to evolve & change dramatically. New music styles and sounds were created and have enriched us like never before.

SONOR realized early on that further development and optimization of sound is only possible when profound research is taken into consideration and implemented in the design process. Analyzing and understanding the physical characteristics of the materials being used in drum manufacturing allows SONOR to keep up with the evolution of music, and stay on top of the game.

In cooperation with the Federal Institute for Physics and Technology in Braunschweig, Germany, we started the first fundamental research of drum anatomy in the 1970s. In countless research sessions the physical characteristics and the interaction of material and components have been investigated: frequencies, resilience, decay, compressive strength, bending strength and the mode of oscillation. The results formed a fundamental knowledge base for some of SONORs most important further developments, some of which hold national or international patent registration:

- APS „Advanced Projection System“
- OSM „Optimized Shell Measurements“
- AcoustiGate
- T.A.R. „Total Acoustic Resonance“ Tom Mounting System
- CLTF „Cross Laminated Tension Free“ Shell Manufacturing Process
- Vertical Grain
- TuneSafe System

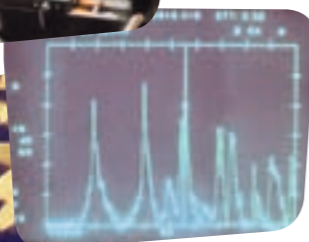

45 degree cut bearing edges

SONOR introduced the 45 degree cut bearing edge to the drumming world in 1975. It's a trademark of all SONOR drums built since then and one of the contributors to the „modern“ SONOR sound. This SONOR innovation has influenced the world of drum building, and is still used today by the majority of drum manufacturers worldwide.



The sharp and narrow bearing edges generate a precise attack, wide dynamics, and a warm fundamental body (depending on the wood type and construction of the shell). The two other ingredients of the SONOR sound are the undersized shell diameters and cross laminated tension free (CLTF) shells.

Optimized Shell Measurements (OSM)

SONOR is using a slightly undersized shell diameter within the Made in Germany item roster. This little detail ensures that the drum head collar and the drums bearing edge meet each other perfectly where it matters. The result is a head that sits flush with the shell, without any wobbling. On SONOR drums the heads profile doesn't need to be stretched and tightened to sit flat on the bearing edge.



All SONOR drums Made in Germany allow the drum head to sit flat which frees the drum breathe into sonic perfection.

This is why SONOR drums are so easy to tune and can be tuned from a very low to a very high pitch without losing their sonic voice.

Cross laminated tension free (CLTF) shells

Since SONOR started manufacturing wooden shells in 1875, SONOR experimented with different shell construction. After much experimenting, SONOR realized that shell rigidity and grain structure were key in achieving a drum sonic capabilities. The existing cross laminated tension free (CLTF) shells were the first shells using vertical grain on the market... period.

The formula of a vertical outside and inside ply, crossing with horizontal plies and other vertical plies within the construction, ensures stiffness and stability in all directions. This allows the shell to resonate as only SONOR shells made in Germany will resonate.

The CLTF process does not require mechanical pressure on the inside of the shell. Due to that only SONOR is able to offer an inside veneer, available in the SQ² custom line of drums.

Rounded bearing edges

For a period of 100 years (1875 - 1975) SONOR was using only rounded bearing edges, along with most other companies as well. SONOR introduced the 45 degree bearing edge in 1975, which we still use today on all SQ2, Prolite, and Force series drums. The rounded bearing edge creates more head contact, which generates a beefier and shorter sound in comparison to the 45 degree cut shells. The result is a warm, dry but yet resonant sound that you'll notice on older drum recordings.

With the addition of the Vintage Series, drummers will have access to a complete palette of sounds that is uniquely SONOR.



Unlike most other drum manufacturers, SONOR developed a special rotating press to apply wraps to the drum shell surface. To eliminate a dampening effect, the wrap is bonded to the shell, creating what is essentially an additional ply which doesn't interfere with the drums natural sound.

SONOR
be unique

14 | 15 **PROLITE SERIES**

ProLite Studio 1 Shell Set in Natural (13106)

Setup: Bass Drum 20" x 17.5" / Tom Tom 10" x 8" /
Tom Tom 12" x 9" / Floor Tom 14" x 14"

Additionally shown: Snare Drum 14" x 5"

Hardware: Cymbal Tom Stand (2x) (CTS 679 MC) /
Snare Drum Stand (SS 677 MC) / Hi-Hat Stand (HH 674 MC) /
Mini Boom Stand (2x) (MBS 673 MC) /
Bass Drum Single Pedal (SP 673)

© Gavin Harrison (Porcupine Tree / King Crimson) Picture by Claudia Hahn



Scan the QR Code to watch
Gavin Harrison's ProLite Performance!

ProLite Series



Raising the bar in
professional
drum making!



The heritage of 140 years of drummaking experience meets the passion, knowledge and creativity of SONOR's international team of design engineers, professional players, distributors and retailers. Using only the finest hand-picked wood selections from eco-friendly resources, precision metal components, and a superior lacquering process, each drum is a piece of art. Made and assembled with care to meet advanced demands and set the bar for professional drums, ProLite combines superior tone, leading-edge design, function and precision to deliver the perfect tools for your musical inspirations. The perfect match for your gig, no matter what style you play!





ProLite Set in Ebony White Stripes (13126)

Setup: Bass Drum 22" x 17.5" (2x) / Tom Tom 10" x 8" / Tom Tom 12" x 9" / Floor Tom 14" x 14" / Floor Tom 16" x 16" / Snare Drum 14" x 6" / Snare Drum 12" x 5"

Hardware: Double Tom Stand (DTS 675 MC) / Snare Drum Stand (2x) (SS 677 MC) / Two-Leg Hi-Hat Stand (HH 684 MC) / Cymbal Boom Stand (CBS 672 MC) / Mini Boom Stand (2x) (MBS 673 MC) / Double Cymbal Stand (2x) (DCS 678 MC) / Bass Drum Single Pedal (2x) (SP 673)

Basic Arm System Components:
BA19 - Bass Drum Adapter (BA19-BDA) / BA - Connection Ratchet (BA-CR) / BA19 - Basic Ratchet (BA19-BR) / BA19 - Basic Arm medium (BA19-M MC) / BA - Basic Clamp (BA-BC)

SONOR ProLite Sound

The core of the ProLite series is the sound spectrum provided by the extremely thin Vintage Maple shells with reinforcement ring. These provide an unmistakably open sound and an enormously wide tuning range for practically all styles of music. SONOR's Vintage Maple shell is characterized by a soft, warm tone that highlights the lower pitches and provides balance in the mid-range and treble, without sacrificing projection and power.

SONOR ProLite Shell Design

SONOR cross-laminates shells for superior stability, sonically enhanced resonance and spectacular tone. The CLTF process is a result of years of research by SONOR craftsmen.

Optimum Shell Measurement (OSM)

SONOR implements a slightly narrow outside shell measurement for optimized head contact. This is a SONOR specialty, resulting in excellent tone, better sustain and controlled decay.

SONOR ProLite Shell Thicknesses

9 plies for tom toms, floor toms and snare drums = 4 mm + 2 mm Dynamic Edge reinforcement rings at the edge of the shells
12 plies for bass drums = 6 mm + 2 mm Dynamic Edge reinforcement rings at the edge of the shells

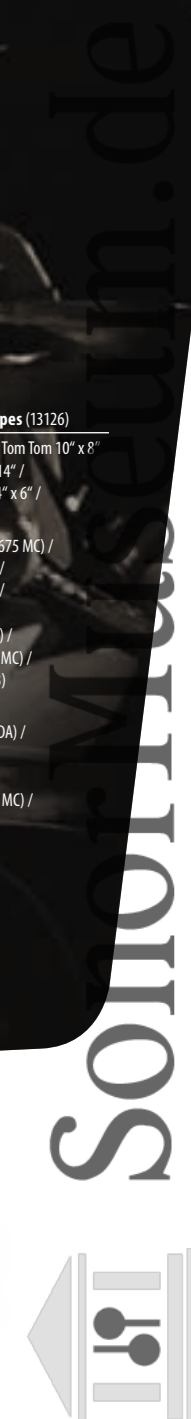

let's talk wood

Besides the shells size, construction, and bearing edge, the wood itself is most important when it comes down to the sound of a drum.

The wood types used on drums all require a certain level of hardness and density. Choosing different materials was historically based on availability in the domestic region where the manufacturer is or was located. In SONOR's case that was German Beech for a very long time. As a matter of fact, Beech is very common all over Germany, and is one of the hardest domestic woods available.

For over a hundred years SONOR chose German Beech as the material for its shells. In the early 1980's Scandinavian Birch was chosen for the SONOR Lite series and was also available within the Signature series. A little later Maple was introduced in the Hilite series (a softer Italian species). In the Delite series SONOR chose to use harder North American Maple, as well as in the first custom series "Designer", which also offered Beech and Birch.

SONOR involves hand craftsmanship where needed, and precision CNC machines (computerized numerical control) where possible to ensure the SONOR quality standard.

The wood types SONOR is using in a short description

North American Maple is a very hard Maple species and offers a mellow, warm and very balanced full tone, providing low frequency punch and a mixed balance of mids and highs. North American Maple is used in SONOR SQ², Prolite and Select Force.

German Beech wood offers a full, warm tone with evenly balanced lows, mids and highs. Tremendous projection, tone and dynamics. German Beech is used in SONOR SQ², Vintage series and Ascent.

Scandinavian Birch is the A-grade amongst Birch species and has an aggressive, distinctive tone with tremendous projection. Providing low and high frequency clarity with a smooth balanced mid range. Scandinavian Birch is used in SONOR SQ².

Additionally in our "Force" series Asian Birch as well as Poplar are used. Poplar is a fast growing wood and is mostly used in beginner to intermediate drum series, or as a filler sandwich layer in between more expensive inner and outer wooden plies. This softer wood generates less precise high and low frequencies in comparison to Maple, Beech or Birch.

The mastery of each drum making starts with the right suppliers, the right storage, the knowledge of selecting matching veneers, the wood mastery and finally the right lacquering knowledge. Please follow us through all the important steps and details in the magic of making a SONOR drum.

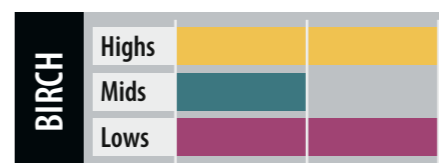
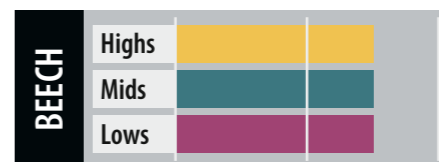
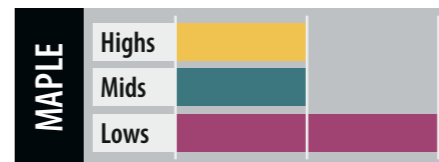

Suppliers

For decades SONOR relies on a number of certified wood and veneer specialists from all over the world. They share the same passion and professionalism as we do. This guarantees a consistent level of wood quality and careful treatment of our natural resources.

Storage

The storage environment for our wood and veneers is optimized to ensure its quality for the shell construction process. Damp wood will warp after contacting the pressing molds, and wood that is too dry will eventually crack. SONOR is utilizing storage which reacts to outside temperatures and humidity and compensates the environment to make sure the wood is at its best when going into production.

VVS (Vertical Veneer System)

SONOR was the first company to introduce and use spectacular vertical veneers on drums which has become a trademark of the company since 1975. Vertical veneer means the veneer's grain is pointing from head to head on the drum, not surrounding the drum which would be called a horizontal veneer grain pattern. Unlike a horizontal grain, a vertical grain requires even more knowledge and precision while choosing and setting the veneer pieces together. SONOR prouls itself as one of the rare masters when it comes to using vertical veneer pattern on drums!

Wood is a naturally grown product, diverse and unique in its pattern and beauty. Vertical veneers are selected, set by hand, and matched for your drum in-house by master craftsmen. Each veneer sheet is one of a kind and makes each drum unique like a fingerprint.

Due to SONOR's own and unique „CLTF“ (see the „Let's talk sound“ column) shell manufacturing process, SONOR is the only company able to offer exotic vertical veneers in the SQ² custom line of drums also inside the shells (except for our Vintage shell construction).

Bass Drum hoops

Our bass drum hoops are made by a German company which also provides wooden steering wheels for Mercedes-Benz and Maybach limousines. These hoops match the beauty of the veneers used on drum shells, don't bend like others do and are extremely sturdy and reliable.

Lacquering

A Special SONOR lacquer formula is used to enhance the wood's natural grain. SONOR uses a rotating drying process for perfect surfaces without lacquer drips. SONOR shells are hand lacquered – 5 high gloss lacquering steps per shell. All shells are sanded and buffed by hand – up to 7 times per shell. This extremely detailed process results in superior brilliance on SONOR's high gloss lacquered shells.



SONOR Museum.de



Prolite Reference

ProLite Bass Drums

Bass Drum	18" x 14"	PL 12 1814 BD WM
Bass Drum	20" x 17.5"	PL 12 2017 BD NM*
Bass Drum	22" x 15"	PL 14 2215 BD NM*
Bass Drum	22" x 17.5"	PL 12 2217 BD NM*
Bass Drum	24" x 14"	PL 14 2414 BD NM

NM* = No Mount / also available with Mount (WM)

ProLite Snare Drums

Maple Snare	12" x 5"	PL 12 1205 SDW
Maple Snare	13" x 5"	PL 12 1305 SDW
Maple Snare	14" x 5"	PL 12 1405 SDW
Maple Snare	14" x 5"	PL 12 1405 SDWD**
Maple Snare	14" x 6"	PL 12 1406 SDW
Maple Snare	14" x 6"	PL 12 1406 SDWD**
Steel Snare	14" x 5"	PL 12 1405 SDS
Brass Snare	14" x 5"	PL 12 1405 SDB
Steel Snare	14" x 5"	PL 12 1405 SDSD**
Brass Snare	14" x 5"	PL 12 1405 SDBD**
Brass Snare	14" x 6"	PL 12 1406 SDBD**

** = with die-cast hoops

ProLite Tom Toms

Tom Tom	8" x 7"	PL 12 0807 TT
Tom Tom	10" x 7"	PL 12 1007 TT
Tom Tom	10" x 8"	PL 12 1008 TT
Tom Tom	12" x 8"	PL 12 1208 TT
Tom Tom	12" x 9"	PL 12 1209 TT
Tom Tom	13" x 10"	PL 12 1310 TT
Tom Tom	14" x 11"	PL 12 1411 TT

ProLite Floor Toms

Floor Tom	14" x 12"	PL 12 1412 FT
Floor Tom	14" x 14"	PL 12 1414 FT
Floor Tom	16" x 14"	PL 12 1614 FT
Floor Tom	16" x 16"	PL 12 1616 FT
Floor Tom	18" x 16"	PL 12 1816 FT

ProLite Preconfigured Shell Sets

ProLite Studio 1 Shell Set	BD 2017 NM, TT 1008, TT 1209, FT 1414
ProLite Stage 2 Shell Set	BD 2217 NM, TT 1008, TT 1209, FT 1414
ProLite Stage 3 Shell Set	BD 2217 NM, TT 1008, TT 1209, FT 1616

NM = No Mount

ProLite Set in Chocolate Burl (17311)

Setup: Bass Drum 22" x 15" / Tom Tom 8" x 7" / Tom Tom 10" x 7" / Tom Tom 12" x 8" / Floor Tom 14" x 12" / Floor Tom 16" x 14" / Snare Drum 14" x 6"

Hardware: Double Tom Holder (DTH 675 MC) / Single Tom Stand (STS 676 MC) / Snare Drum Stand (SS 677 MC) / Hi-Hat Stand (HH 674 MC) / Mini Boom Stand (4x) (MBS 673 MC) / Bass Drum Single Pedal (PB Perfect Balance) / Drummer's Throne round seat (DT 6000 RT)

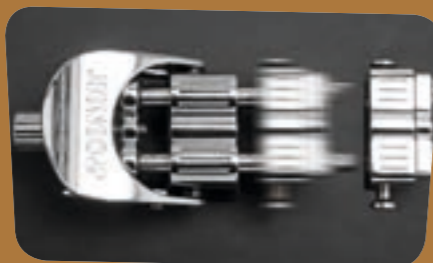

Dual Glide Snare Strainer

The strainer features a technically perfected snare wire „On/Off“ function, along with a Quick Release system for fast and easy exchange of snare wires, great adjustability and a solid look and feel.

(Snare quick release used under license from Dunnett US patent 7745712)

Bass Drum Claws – Beautiful and Practical

The rubber insert beneath the bass drum claws assures that your wooden hoop will not be scratched. The recessed design of the tension rod and the raised synthetic insert of the bass drum claw protect your cases from snagging and scratching damage.

Drumheads Made by REMO® USA

Tom Toms / Floor Toms: Ambassador Clear
 Snare Drums: Ambassador White Coated / Ambassador Resonant
 Bass Drums: Powerstroke3 Clear, Powerstroke3 Black with white SONOR logo except for Natural and Nussbaum Finish - Powerstroke3 White with black SONOR logo.

(T.A.R.) Total Acoustic Resonance Mounting System

Vibration free mounting results in pure tone and warm sustain. Enhanced by Total Acoustic Resonance and Advanced Projection System your Drum enjoys sonic freedom and stays mechanically stable, resulting in beautiful tone and unmatched projection.





ProLite Set in Creme White (13104)

Setup: Bass Drum 22" x 17.5" / Tom Tom 10" x 8" / Tom Tom 12" x 9" / Floor Tom 14" x 14" / Floor Tom 16" x 16" / Snare Drum 14" x 6" / Snare Drum 12" x 5"

Hardware: Cymbal Tom Stand (2x) (CTS 679 MC) / Snare Drum Stand (2x) (SS 677 MC) / Hi-Hat Stand (HH 674 MC) / Cymbal Boom Stand (CBS 672 MC) / Mini Boom Stand (2x) (MBS 673 MC) / Bass Drum Double Pedal (DP 672)



ProLite Stage 2 Shell Set in Brilliant Black (11255)

Setup: Bass Drum 22" x 17.5" / Tom Tom 10" x 8" / Tom Tom 12" x 9" / Floor Tom 14" x 14"

additionally shown: Snare Drum 14" x 6"

Hardware: Cymbal Tom Stand (2x) (CTS 679 MC) / Snare Drum Stand (SS 677 MC) / Hi-Hat Stand (HH 674 MC) / Mini Boom Stand (MBS 673 MC) / Bass Drum Single Pedal (SP 673)



SONORMUSIC.COM

ProLite Set in Silver Sparkle (13107)

Setup: Bass Drum 22" x 17.5" / Tom Tom 12" x 9" / Floor Tom 16" x 16" / Snare Drum 14" x 6"

Hardware: Single Tom Stand (STS 676 MC) / Snare Drum Stand (SS 677 MC) / Hi-Hat Stand (HH 674 MC) / Cymbal Boom Stand (CBS 672 MC) / Mini Boom Stand (2x) (MBS 673 MC) / Bass Drum Single Pedal (SP 673)



Jost Nickel (Jan Delay) Picture by Marco Hammer



Did you know?
SONOR was the 1st company to introduce 45 degree Bearing Edges in 1975. The result is a precise drumhead-to-shell-contact which allows for more tone.

ProLite Set in Blue Sparkle (10821)

Setup: Bass Drum 24" x 14" / Tom Tom 13" x 10" / Floor Tom 16" x 16" / Floor Tom 18" x 16" (PL 12 1816 FT) / Snare Drum 14" x 6"

Hardware: Single Tom Stand (STS 676 MC) / Snare Drum Stand (SS 677 MC) / Hi-Hat Stand (HH 674 MC) / Mini Boom Stand (4x) (MBS 673 MC) / Bass Drum Single Pedal (PB Perfect Balance)



Recommended

Build to last: the 600 Series is the perfect fit for your ProLite Series kit!



www.sonormuseum.de



Chocolate Burl
Veneer High Gloss (17311)



Ebony White Stripes
Veneer High Gloss (13126)



Walnut Brown Burst
Veneer High Gloss (13087)



Nussbaum
Stain Satin Gloss (13105)



Creme White
Solid Matte (13104)



Brilliant Black
Solid High Gloss (11255)



Silver Sparkle
Sparkle High Gloss (13107)



Blue Sparkle
Sparkle High Gloss (10821)



Natural
Stain Satin Gloss (13106)



ProLite Stage 3 Shell Set in Walnut Brown Burst (13087)

Setup: Bass Drum 22" x 17.5" / Tom Tom 10" x 8" / Tom Tom 12" x 9" / Floor Tom 16" x 16"
additionally shown: Snare Drum 14" x 5"

additionally shown Hardware: Cymbal Tom Stand (2x) (CTS 679 MC) / Snare Drum Stand (SS 677 MC) / Hi-Hat Stand (HH 674 MC) / Mini Boom Stand (2x) (MBS 673 MC) / Bass Drum Single Pedal (SP 673)



ProLite Set in Nussbaum (13105)

Setup: Bass Drum 18" x 14" / Tom Tom 12" x 8" / Floor Tom 14" x 14" / Snare Drum 13" x 5"

Hardware: Single Tom Holder (STH 674 MC) / Snare Drum Stand (SS 677 MC) / Hi-Hat Stand (HH 674 MC) / Mini Boom Stand (2x) (MBS 673 MC) / Bass Drum Single Pedal (SP 673)

Connie Kay

Switzerland

Christoph Blattner > Rhythmtalk
Pesche „DeeDee“ Kaufmann > George
Pit Lee > Da Cruz
Noby Lehmann > Rhythmtalk
Ruedi Maurer > Rhythmtalk
Jojo Mayer > Nerve
Philipp Schmid > Independent
Muso Stamm > Independent
Tom Steinmann > Treekillaz
Thomas Wild > van Dango, Schmetterband
Guido Wyss > Enigmatik
Domenic Schüpbach > Yokko
Simon Steiner > Redeem
Remo Signer > Michael von der Heide, Bruno Hächler
Sascha Weber > Purpur, Setup
Ephraim Salzmann > Stefanie Heinzmann
Roberto Bianchetti > Sinplus
Christoph Fluri > Chica Torpedos
Dany Schnyder > Independent
Sandro Oberholzer > Independent
Tobias Heim > Kummerbuben, Tomazobi
Fabian Bürgi > Tequila Boys
Simon Baumann > Stephan Eicher

New Zealand

Patrick Kuhlitz > Independent
Darren Mathiassen > Shapeshifter / Hollie Smith
Phil Rudd > AC/DC

Taiwan

Ming > Mayday

Malaysia

Martin Ngim > Independent

Australia

Joe Accaria > Jimmy Barnes/David Campbell
Ben Hall > The Butterfly Effect
Dave Goodman > James Morrison
Joel Mammon AKA KUSTOM > Mr. Bill/Independent
Kevin Mendoza > Jessica Mauboy
Evan Yako > Recording Artist

USA

Nasar Abadey > Independent
Tal Bergman > Joe Bonamassa
David Bowen > Cody Canada & the Departed
Jaimeo Brown > Jaimeo Brown Trio
Wild Mick Brown > Ted Nugent
Rocky Bryant > Average White Band
Dino Campanella > Dredg
Danny Carey > Tool
Chris Coleman > Prince
Paul Collier > Angelcorpse
Asoka Compton > Independent
Duduka Da Fonseca > Independent
Jack DeJohnette > Independent
Arti Dixson > Independent
Dave Ferrara > Reach Around Rodeo Clowns
Vinnie Fiorello > Less Than Jake
Ian Froman > Independent
Derrick Frost > Chiodos
Howie Gordon > Broadway
Kris Gustofson > Independent
Aaron Harris > Isis / Palms
Tootie Heath > The Heath Brothers
Mark Hernandez > Forbidden
Orlando Hernandez > Chyanne
Yoron Israel > Independent
Fernando Jaramillo > Chyanne
Jeffrey Jones > Independent
Dean Kosh > Airborne
Glenn Kotche > Wilco
Rick Leith > One Slack Mind
Shannon Leto > 30 Seconds to Mars
Armand Majidi > Sick Of It All
Samantha Maloney > Independent
Sammy Merendino > Cyndi Lauper
John Miceli > Meat Loaf
Adam Nussbaum > The Impossible Gentlemen
David Piribauer > Independent
Kim Plainfield > Independent
Nat Scott > Independent
Leah Shapiro > Black Rebel Motorcycle Club
Jared Shavelson > Boysetsfire
Jeff Sipe > Jimmy Herring
Neal Smith > Independent
Steve Smith > Vital Information
Kenny Soule > Independent
Miike Starcher > Independent
David Thaler > Bad Influence
Larry Thompson > Independent
T. J. Thorn > Independent
Ed Udhus > Zebrahead
Dan Uosikinen > The Hooters
Nathan Walker > Lit Kobe Watkins > Sonny Rollins
Jeff Tain Watts > Independent
Ron Wikso > Greg Rolie
Joe Winters > Steepwater Band
Drummie Zeb > The Waitlers

China

Guan Fei > Wang Feng Band
Liu Gang > C.N.S.O
Zheng Zhaohui Hao Zi > Independent
Lu Xun > China Drummer Association

France

Mickaël Boudoux > Independent
Frederic Degré > Independent
Claude Gastaldin > Independent
Jo Hammer > Independent
Marc Jacquemin > Cock Robin – FLOX
Christian Monthieux > FFF - Independent
Paco Sery > SIXUN
Maxime Zampieri > Independent

Austria

Klaus Brennstener > Parametrix
Werner Groisz > Independent
Christian Lettner > Basic Jazz Lounge
Reinhard Schwarzinger > Independent

Benelux

Herman Cambré > Clouseau
René Creemers > Drumbassadors
Wim De Vries > Drumbassadors
Hans Eijkenaar > The Voice Of Holland
John Engels > Independent
Mark Eshuis > Independent
Arend Nijs > Independent
Juan van Emmerloot > Stef Burns
Stephen van Haestregt > Independent
Gregory Pantophlet > Independent
Sander Zoer > Delain

Canada

Jeff Asselin > Independent
Jim Boudreau > The Western Swing Authority
Emmanuelle Caplette > Independent
Steve Caron > Radio Radio
Sean Dalton > The Trews
Aubrey Dayle > My id
Davide DiRenzo > Independent
Aaron Edgar > Third Ion
Johnny Fay > The Tragically Hip
Rich Irwin > Florence K
Chuck Keeping > Big Wreck
Dave Langguth > Independent
Chris Lesso > Modus Factor
Anthony Michelli > Independent
Dave Patel > Emmanuel Jal
Pat Steward > Odds
Tyler Stewart > Barenaked Ladies
Chris Sutherland > The Road Hammers
Tim Timleck > Carole Pope
Roger Travassos > Michael Kaeshammer
Max Trefler > The Mohrs

Germany

Florian Alexandru-Zorn > Independent
Christian Blüm > Brings
Ronny Dehn > Silly
Stephan Emig > Triosence
Benny Greb > Moving Parts
Carola Grey > Noisy Mama
Holger Hälbig > Independent
Rennie Hatzke > Münchener Freiheit
Eike Herwig > Donots
Sebastian Krajewski > Seeed / Peter Fox
Raffael Kühle > OK Kid
Thomas Lieven > Big Band der BW
Rudi Marhold > Götz Alsmann
Ralf Neuhaus > Independent
Jost Nickel > Jan Delay
Andreas Nowak > Silbermond
Dennis Poschwatta > Guano Apes
Pola Roy > Wir sind Helden
Klaus Scharfschwerdt > Puhdys
Christoph Schneider > Rammstein
Ralph Winter > Big Band der BW
Michael Wolpers > Victory

United Kingdom

Steve Alexander > Independent
Craig Bacon > Independent
Richard Bailey > Incognito
Ian Bayne > Runrig
Gene Calderazzo > Independent
Dane Campbell > Straight Lines
Jack Carrack > Paul Carrack
Joe Crabtree > Wishbone Ash
Danny Cummings > Mark Knopfler
Blair Cunningham > Westernhagen
Guy Davis > Freeze the Atlantic
Dave DeRose > Moloko/Roisin Murphy
Martin Ditcham > Westernhagen / Status Quo
Gabor Dornyei > Independent
Dean Duke > Paul Carrack
Josh Gimber > Sons and Lovers
Gavin Harrison > Porcupine Tree / King Crimson
Ryan Jenkinson > Reverend & the Makers
Martin "Magic" Johnson > Bewitched
Jan Kincaid > Brand New Heavies
Vinnie Lammie > Mel C / Spice Girls
Ed Lay > Editors
Dafydd Leuan > Super Furry Animals
John Marshall > Soft Machine Legacy
Bryan McLellan > 24 Pesos
Perry Melius > Tricky / Billy Ocean
Brendan O'Neill > Nine Below Zero
Alexis Nunez > The Kooks
Chris "Jungle" Polglase > Independent
Alex Reeves > Dizzee Rascal
Andy Robertson > Marlon Roudette
Arnaldo Rogano > Future Shock
Rocky Singh > Asian Dub Foundation
Henry Spinetti > Katie Melua / Eric Clapton
Richard Thair > Red Snapper
Alex Toff > Jack McManus
Paul Walsham > Hurts / Barclay James Harvest
Colin Woolway > Independent

Italy

Enzo Augello > Educator
Lele Boria > Educator
Gianni Caltran > Session
Francesco Corvino > Session
Andrea Ge > Independent
Riccardo Lombardo > Independent
Claudio Mastracci > Independent
Fabio Nobile > Session
Federico Paulovich > Destrage
Franco Penatti > Session
Sergio Pescara > Groovydo
Daniele Pomo > RanestRane
Giorgio Prette > Independent
Franco Rossi > Educator
Danilo Tasco > Negramaro

Argentina

Pablo Laporta > Independent
Gustavo Meli > Independent
Jota Morelli > Independent
Andres Vilanova > Carajo

Norway

Rune Arnesen > Independent
Jan Axel «Hellhammer» Blomberg > Mayhem
Ole Petter Hansen Chyllie > Dream Police / Ingrid Bjørnov/
Beat for Beat
Anders Engen > Bjørn Eidsvåg
Claus Heiberg > Briskeby
Sola Johnsen > Dum Dum Boys / Helter Skelter
Espen Mangan > Independent
Kim Ofstad > Dsound / Madcon
Bjørn Gunnar Sando > Hellbillies
Agne Sæter > CC Cowboys

Sweden

Mikkey Dee > Motörhead
Tomas Haake > Meshuggah

Japan

Yuki Aoyama > nano,RIPE
Masao Fukunaga > Nana Mizuki
Genta > Orquesta De La Luz, Masayoshi Yamazaki
Naoya Hamada > Independent
Yuki Hatano > YELLow
Yuichi Hokazono > Spicy Kickin'
Osamu Jinguji > Remioromen
Kou > Pe'Z
Taro Koyama > Independent
Ken Ken Sato > Plastic Tree
Yoshitaka Shirane > Krewa
Akira Suefusa > Ego Wrappin' and the Gossip of Jaxx
Masaaki Tamaki > Rimi Natsukawa, TUBE
Yutaka Watanabe > Independent
Hideo Yamaki > Independent
Yuzo Yoshioka > Monster-Tairiku

India

Ranjit Barot > John McLaughlin

Indonesia

Amos > GMB
Hendi > GiGi
Cendi Luntungan > CC and The Funky Stuff
Yon Pilyang > Session Player
Echa Soemantri > Session Player

Christoph Schneider (Rammstein), Photo by Olaf Heine

the revival of the famous beech shell

The SONOR Ascent series marks the revival of the famous Beech shell construction that has been a trademark of SONOR throughout the decades.



Equipped with the latest features and technology, the Ascent series is the perfect bridge between the Select Force Series and the Vintage and ProLite series, providing the timeless quality and tremendous sound that Sonor is famous for. Stunning veneers and solid lacquered finishes highlight the high end look of the Ascent series. In addition, select finishes are accompanied by black chrome fittings – a feature taken from SONOR's premium SQ2 series.



Coral Red (17313)



Matte Black (17312)



Natural (13077)



Burnt Fade (13079)



Creme White (13084)



Ebony Stripes (13078)



Dark Natural (13080)

Ascent Series Sounds

SONOR's design team worked closely with some of the top Sonor artists to create the ultimate shell specifications for premium sound. Implementing thin Beech shells for bass drums and thick Beech shells for snare drums, tom toms and floor toms results in a full, rich tone that is powerful and well-balanced. No matter where you play, the woodshed, the recording studio or the stage, you'll lay down a perfect performance with SONOR's Ascent series.

Shell Construction	9 plies (8.75 mm) for Tom Toms, Floor Toms and Snare Drums 7 plies (6.35 mm) for Bass Drums
Hoops	2.3 mm Power Hoops on all Tom Toms and Floor Toms 14" Snare Drums with Die Cast Hoops
Hardware Components	Tuning Lugs equipped with TuneSafe, prevents tension rods from loosening Vibration-free T.A.R. Tom Mounting System Standard Ascent Series Bass Drum without mount, optional mount available Rubber padded Bass Drum claws Bass Drum spurs with memory locks Bass Drum feet convertible from rubber to metal spike
REMO® Drumheads	Made by REMO USA, Tom Toms: Ambassador Clear, Snare Drums: Ambassador White Coated, Ambassador Resonant, Bass Drums: Powerstroke3 Clear, Powerstroke3 Black with SONOR Logo

Ascent Reference

Ascent Bass Drums		
Bass Drum	20" x 18"	ASC 11 2018 BD NM
Bass Drum	22" x 18"	ASC 11 2218 BD NM
NM = No Mount		

Ascent Snare Drums		
Steel Snare	14" x 5.5"	ASC 11 1455 SDSD*
Beech Snare	14" x 5.5"	ASC 11 1455 SDWD*
Beech Snare	14" x 6.5"	ASC 11 1465 SDWD*
* = with die-cast hoops		

Ascent Tom Toms		
Tom Tom	8" x 7"	ASC 11 0807 TT
Tom Tom	10" x 8"	ASC 11 1008 TT
Tom Tom	12" x 9"	ASC 11 1209 TT

Ascent Floor Toms		
Floor Tom	14" x 14"	ASC 11 1414 FT
Floor Tom	16" x 16"	ASC 11 1616 FT

Ascent Preconfigured Shell Sets	
Ascent Studio Set	BD 2018 NM, SD 1455, TT 1008, TT 1209, FT 1414, 5-pc. HW 400 Set, 2 x MC 276, 2 x TA 4000
Ascent Stage 2 Set	BD 2218 NM, SD 1455, TT 1008, TT 1209, FT 1414, 5-pc. HW 400 Set, 2 x MC 276, 2 x TA 4000
Ascent Stage 3 Set	BD 2218 NM, SD 1455, TT 1008, TT 1209, FT 1616, 5-pc. HW 400 Set, 2 x MC 276, 2 x TA 4000
Ascent Jazz Set	BD 1814 WM, SD 1465, TT 1208, FT 1414, 5-pc. HW 400 Set, STH 4000

NM = No Mount / WM = with Mount

Ascent Stage 3 Set NM in Matte Black (17312)

Finish with Black Chrome Shell Hardware:
Bass Drum 22" x 18" / Snare Drum 14" x 5.5" /
Tom Tom 10" x 8" / Tom Tom 12" x 9" / Floor Tom 16" x 16"
Hardware: Tom Arm (2x) (TA 4000) /
Multi Clamp (2x) (MC 276) / Hardware 400 Set (HS 400)



Did you know?

Beech wood, harvested in Germany, has been the main wood material used by SONOR from the very early days of drum manufacturing and is used till today, not only in our „Ascent“ Series, but also in our Vintage and custom SQ2 series!

the cool way to join the professionals

The SONOR Select Force series is the pinnacle of the Force range, featuring an all-maple shell. Designed with advanced and semi-professional drummers in mind, the Select Force Series can also be an interesting alternative for professional drummers. An array of pre-configured sets, components and the latest design in hardware and fittings make the SONOR Select Force series a recommended choice for the serious player!

Select Force Sounds

The 7 ply Canadian Maple shells offer uncompromisingly rich and warm sounds, highlight lower pitches and provide balance in the mid-range and treble. Whether in the woodshed, recording studio or on stage, SONOR's Select Force sets deliver a powerful performance every time.

- Shell Construction** 7 plies (5.8 mm) for Tom Toms, Floor Toms and Snare Drums
7 plies (7.2 mm) for Bass Drums
- Hoops** 2.3 mm Power Hoops on all Snare Drums
- Hardware Components** Tuning Lugs equipped with TuneSafe, prevents tension rods from loosening
Vibration-free T.A.R. Tom Mounting System
Rubber padded Bass Drum claws
Bass Drum spurs with memory locks
Bass Drum feet convertible from rubber to metal spike
- REMO® UT Drumheads** Tom Toms/Floor Toms: Emperor Style Clear, Snare Drums: Ambassador Style White Coated, Ambassador Style Resonant, Bass Drums: Powerstroke3 Style Clear, Powerstroke3 Style Black with SONOR Logo

Select Force Reference

Select Force Bass Drums		
Bass Drum	18" x 16"	SEF 11 1816 BD WM
Bass Drum	20" x 17.5"	SEF 11 2017 BD WM
Bass Drum	22" x 17.5"	SEF 11 2217 BD WM
Bass Drum	22" x 20"	SEF 11 2220 BD NM

NM = No Mount / WM = with Mount

Select Force Snare Drums		
Jungle Snare	10" x 2"	SEF 11 1002 SDJ
Maple Snare	13" x 7"	SEF 11 1307 SDW
Maple Snare	14" x 5.5"	SEF 11 1455 SDW
Steel Snare	14" x 5.5"	SEF 11 1455 SDS
Maple Snare	14" x 6.5"	SEF 11 1465 SDW

Select Force Tom Toms		
Tom Tom	8" x 7"	SEF 11 0807 TT
Tom Tom	10" x 8"	SEF 11 1008 TT
Tom Tom	12" x 9"	SEF 11 1209 TT

Select Force Toms		
Floor Tom	14" x 14"	SEF 11 1414 FT
Floor Tom	16" x 16"	SEF 11 1616 FT

Select Force Preconfigured Shell Sets		
Select Force Studio Set	BD 2017 WM, SD 1455, TT 1008, TT 1209, FT 1414, 5-pc. HW 400 Set, DTH 4000	
Select Force Stage 2 Set	BD 2217 WM, SD 1455, TT 1008, TT 1209, FT 1414, 5-pc. HW 400 Set, DTH 4000	
Select Force Stage 3 Set	BD 2217 WM, SD 1455, TT 1008, TT 1209, FT 1616, 5-pc. HW 400 Set, DTH 4000	
Select Force S Drive Set	BD 2220 NM, SD 1465, TT 1065, TT 1207, FT 1412, FT 1614, 5-pc. HW 400 Set, 2 x MC 276, 2 x TA 4000	
Select Force Jungle Set	BD 1616 WM, TT 1008, FT 1412, STH 4000	

NM = No Mount / WM = with Mount

Recommended
4000-Series Hardware Set
— Reliable and Sturdy 'On the Road'!
The Hardware 4000 series provides road-ready double-braced stands with clever player-oriented solutions for maximum versatility, stability and reliability.



Smooth Brown Burst (13008)



Autumn Fade (11237)



Maple (11238)



Dark Forest Burst (13074)



Transparent Black Burst (13113)



Piano Black (11234)



Blue Galaxy Sparkle (13034)



Brown Galaxy Sparkle (13036)



Leah Shapiro (Black Rebel Motorcycle Club)

Select Force Stage 5 Drive Set NM in Transparent Black Burst (13113)

Setup: Bass Drum 22" x 20" / Snare Drum 14" x 6.5" / Tom Tom 10" x 6.5" / Tom Tom 12" x 7" / Floor Tom 14" x 12" / Floor Tom 16" x 14"

Hardware: Tom Arm (2x) (TA 4000) / Multi Clamp (2x) (MC 276) / Hardware 400 Set (HS 400)



Did you know?

Our Ascent Series as well as Select and Essential Force Series feature our own T.A.R. (Total Acoustic Resonance) Tom Mounting System - Powerful sounds thanks to minimal shell contact!

Color choices may differ from country to country

Essential Force Studio Set WM in Creme White (13084)

Setup: Bass Drum 20" x 17.5" / Snare Drum 14" x 5.5" / Tom Tom 10" x 8" / Tom Tom 12" x 9" / Floor Tom 14" x 14"

Hardware: Double Tom Holder (DTH 4000) / Hardware 200 Set (HS 200)



Piano Black (11234) Creme White (13084)

*optimum
playing
comfort*
with professional features



The SONOR Essential Force series features a birch wood shell and is designed for advanced drummers not wanting to sacrifice their musical freedom. Five pre-configured sets and several components offer an array of possibilities for customizing configurations.

SONOR Essential Force Sounds

The 6 ply birchwood shells are a superb foundation for SONOR Essential Force sets. A hefty and dynamic sound – with accentuated mid-ranges and highs, and defined lows – are the hallmark of these shells. With high-gloss-lacquered natural wood surfaces, SONOR's Essential Force really steals the show.



Fade Blue (11235)



Amber Fade (11236)



Green Fade (13072)



Brown Fade (13073)



Birch (11233)

- Shell Construction** 6 plies (7.2 mm) for Bass Drums, Tom Toms, Floor Toms and Snare Drums
- Hardware Components** Tuning Lugs equipped with TuneSafe, prevents tension rods from loosening
Vibration-free T.A.R. Tom Mounting System
Rubber padded Bass Drum claws
Bass Drum spurs with memory locks
Bass Drum feet convertible from rubber to metal spike
- REMO® UT Drumheads** Tom Toms/Floor Toms: Emperor Style Clear; Snare Drums: Ambassador Style White Coated, Ambassador Style Resonant; Bass Drums: Powerstroke3 Style Clear, Powerstroke3 Style Black with SONOR Logo

Essential Force Reference

Essential Force Bass Drums		
Bass Drum	20" x 17.5"	ESF 11 2017 BD WM
Bass Drum	22" x 17.5"	ESF 11 2217 BD WM
Bass Drum	22" x 20"	ESF 11 2220 BD NM
NM = No Mount / WM = with Mount		
Essential Force Snare Drums		
Birch Snare	14" x 5.5"	ESF 11 1455 SDW
Steel Snare	14" x 5.5"	ESF 11 1455 SDS
Birch Snare	14" x 6.5"	ESF 11 1465 SDW

Essential Force Tom Toms		
Tom Tom	8" x 7"	ESF 11 0807 TT
Tom Tom	10" x 8"	ESF 11 1008 TT
Tom Tom	12" x 9"	ESF 11 1209 TT
Tom Tom	13" x 10"	ESF 11 1310 TT
Essential Force Toms		
Floor Tom	14" x 14"	ESF 11 1414 FT
Floor Tom	16" x 16"	ESF 11 1616 FT

Essential Force Preconfigured Shell Sets		
Essential Force Studio Set	BD 2017 WM, SD 1455, TT 1008, TT 1209, FT 1414,	5-pc. HW 200 Set, DTH 4000
Essential Force Stage 2 Set	BD 2217 WM, SD 1455, TT 1008, TT 1209, FT 1414,	5-pc. HW 200 Set, DTH 4000
Essential Force Stage 3 Set	BD 2217 WM, SD 1455, TT 1008, TT 1209, FT 1616,	5-pc. HW 200 Set, DTH 4000
Essential Force S Drive Set	BD 2220 NM, SD 1465, TT 1065, TT 1207, FT 1412,	FT 1614, 5-pc. HW 200 Set, 2 x MC 276, 2 x TA 4000

NM = No Mount / WM = with Mount

Color choices may differ from country to country



Did you know?
Our Ascent Series as well as Select and Essential Force Series Bass Drums are equipped with rubber padded bass drum claws to protect the wooden hoop against damage.



Black (11229)

Brushed Blue (13004)

Wine Red (11228)



Smart Force Studio Set WM in Brushed Blue (13004)

Setup: Bass Drum 20" x 17.5" / Snare Drum 14" x 5.5" / Tom Tom 10" x 8" / Tom Tom 12" x 9" / Floor Tom 14" x 14"

Hardware: Double Tom Holder (DTH 2000) / 4-piece Hardware Set

Smart Force Reference

Smart Force Snare Drums

Steel Snare 14" x 5.5" SMF 11 1455 SDS

Smart Force Preconfigured Sets

Smart Force Combo Set BD 1816 WM, SD 1455, TT 1008, TT 1209, FT 1414, 4-pc. Hardware Set, DTH 2000

Smart Force Studio Set BD 2017 WM, SD 1455, TT 1008, TT 1209, FT 1414, 4-pc. Hardware Set, DTH 2000

Smart Force Stage 1 Set BD 2217 WM, SD 1455, TT 1209, TT 1310, FT 1616, 4-pc. Hardware Set, DTH 2000

Smart Force Stage 2 Set BD 2217 WM, SD 1455, TT 1008, TT 1209, FT 1414, 4-pc. Hardware Set, DTH 2000

WM = with Mount



Did you know?

All SONOR lugs are equipped with the patented TuneSafe, which prevents the tension rods from loosening. TuneSafe supports maximum tuning stability even under extreme environments. Square-head tension rods with fine-pitch threads guarantee optimum tunability.

The SONOR Smart Force series has been designed with the beginner in mind, offering an attractive price point without compromising quality and sound. Offered in several stunning coverings and pre-configured sets, the SONOR Smart Force is the ideal choice for all up-and-coming rockers, jazz cats, enthusiasts of metal or blues ... or any drummer who's looking for a Drum set that is sturdy, yet versatile.

*off to
the right
start*



SONOR Smart Force Sounds

The 9 ply Poplar shells of the SONOR Smart Force sets are full bodied, providing balanced sound with lots of power up front. SONOR Smart Force Shell Design The Poplar shells deliver maximum strength, perfect roundness, and neutral Tuning thanks to the tension-free cross-lamination of the individual plies of wood (CLTF Cross Laminated Tension Free Process). The covered finish is very sturdy and long lasting, and the workmanship is impeccable.

Shell Construction

9 plies (7.2 mm) for Bass Drums, Tom Toms, Floor Toms and Snare Drums

Hardware Components

Tuning Lugs equipped with TuneSafe, prevents tension rods from loosening
Bass Drum feet convertible from rubber to metal spike
New Double Tom Holder with Ball Clamp

REMO® UX Drumheads

Tom Toms/Floor Toms: Ambassador Style Clear, Snare Drums: Ambassador Style Clear, Ambassador Style Resonant, Bass Drums: Powerstroke3 Style Clear, Powerstroke3 StyleBlack with SONOR Logo



Smart Force Xtend Studio Set WM in Wine Red (11228)

Setup: Bass Drum 20" x 17.5" / Snare Drum 14" x 5.5" / Tom Tom 10" x 8" / Tom Tom 12" x 9" / Floor Tom 14" x 14"

Hardware: Double Tom Holder (DTH 2000) / 4-piece Hardware Set / Mini Boom Stand (MBS 53) / Drummer's Throne, round seat (DT 270) / Cast B8 Cymbals, 14" Hi-Hat / 16" Crash and 20" Ride (CB8 Set 1)

Smart Force Xtend kits include additional Mini Boom Stand, Drum Throne and Cast Cymbal Set.

Smart Force Xtend Reference

Smart Force Xtend Bundle Sets

Smart Force Xtend Combo Bundle Set BD 1816 WM, SD 1455, TT 1008, TT 1209, FT 1414, 4-pc. Hardware Set, DTH 2000, MBS 53, DT 270, CB8 Cymbal Set (14HH, 16C, 20R)

Smart Force Xtend Studio Bundle Set BD 2017 WM, SD 1455, TT 1008, TT 1209, FT 1414, 4-pc. Hardware Set, DTH 2000, MBS 53, DT 270, CB8 Cymbal Set (14HH, 16C, 20R)

Smart Force Xtend Stage Bundle Set BD 2217 WM, SD 1455, TT 1008, TT 1209, FT 1414, FT 1616, 4-pc. Hardware Set, DTH 2000, MBS 53, DT 270, CB8 Cymbal Set (14HH, 16C, 20R)

Smart Force Xtend Stage 1 Bundle Set BD 2217 WM, SD 1455, TT 1209, TT 1310, FT 1616, 4-pc. Hardware Set, DTH 2000, MBS 53, DT 270, CB8 Cymbal Set (14HH, 16C, 20R)

Smart Force Xtend Stage 2 Bundle Set BD 2217 WM, SD 1455, TT 1008, TT 1209, FT 1414, 4-pc. Hardware Set, DTH 2000, MBS 53, DT 270, CB8 Cymbal Set (14HH, 16C, 20R)

Smart Force Xtend Tom Pack TT 0807, MC 276, TA 278

WM = with Mount



Red Galaxy Sparkle

Turquoise Galaxy Sparkle

Silver Galaxy Sparkle

Gold Galaxy Sparkle

Black Galaxy Sparkle

SMALL CAR? SMALL STAGE? *don't* SMALL APARTMENT?
sacrifice your sound

Our new Martini, Safari, Bop and Players kits offer compact size shells, but at the same time uncompromised sound. All drum kits feature a poplar shell combined with a covered sparkle finish and a tom holder. Cross-Laminated shells deliver superior stiffness, sonically pleasing resonance and spectacular tone. Tune Safe equipped lugs ensure that the tuning stays in place.



Martini Special Edition in Turquoise Galaxy Sparkle (13119)

Setup: Bass Drum (with Mount & Riser) 14" x 12" / Tom Tom 8" x 8" / Floor Tom 13" x 10" / Steel Snare Drum 12" x 5"

Hardware: Single Tom Holder (STH 274)

Colors: Turquoise Galaxy Sparkle (13119) / Gold Galaxy Sparkle (17319) / Red Galaxy Sparkle (13116)

Did you know?

The approx. height of a full-grown Martini Special Edition kit is 80 cm (Standard setup, measured from floor to the top hoop of the tom tom), a full-grown Saint Bernard dog up to 90 cm in comparison.



Safari Special Edition in Red Galaxy Sparkle (13116)

Setup: Bass Drum (with Mount & Riser) 16" x 16" / Tom Tom 10" x 8" / Floor Tom 14" x 12" / Snare Drum 14" x 5"

Hardware: Single Tom Holder (STH 274)

Colors: Red Galaxy Sparkle (13116) / Black Galaxy Sparkle (12795) /



Bop Special Edition in Silver Galaxy Sparkle (12796)

Setup: Bass Drum (with Mount) 18" x 16" / Tom Tom 12" x 8" / Floor Tom 14" x 14" / Snare Drum 14" x 5"

Hardware: Single Tom Holder (STH 274)

Colors: Silver Galaxy Sparkle (12796) / Red Galaxy Sparkle (13116)



Players Special Edition in Black Galaxy Sparkle (12795)

Setup: Bass Drum (with Mount) 20" x 12" / Tom Tom 10" x 8" / Floor Tom 14" x 12" / Snare Drum 14" x 5"

Hardware: Cymbal / Tom Combination Holder

Colors: Black Galaxy Sparkle (12795)

Florian Alexandru-Zorn



moimuseum.de

the heart

SONOR snare drum from the 1960s

Christian Lettner (Basic Jazz Lounge / Passport)

of every beat

The snare drum is at the heart of every beat, centering the drum set with the most musical voice in your set-up. It's also the game changer in any musical setting – change the snare drum, and the band has a completely different sound. Get inspired by playing one of the finest instruments available to drummers today – SONOR snare drums!

sonorMuseum.de



The exclusive SONOR Artist Snare series combines the experience of the world's most talented drummers with SONOR's vast percussion instrument manufacturing expertise. This partnership has produced unparalleled snare drum models which meet even the most stringent demands.

From brass to steel or bronze, from maple to beech and birch, each and every Artist Snare Drum is a masterpiece in its own right. During the development process, design is as integral to the final product as sound quality. This attention to detail gives each Artist Snare Drum its own unmistakable character. See for yourself on the following pages, or visit your SONOR instrument dealer to experience the tremendous quality of SONOR Artist Snares.

the very best snares

AS 12 1205 AD „Art Design“

A 12 ply Birch shell with 12" x 5" size gives this snare drum a crisp, bright sound with plenty of attack. Whether using it as the main drum or as a side snare drum, the high pitched rim shots and sensitive response of the stainless steel wires ensure perfect sound performance. Ideal for the short breaks in drum 'n' bass, hip-hop or electronic pop.

Features: 12 ply Birch shell, 7 mm shell thickness, 45° bearing edge, high gloss lacquer finish, 16 tension rods, TuneSafe, Dual Glide snare action, chrome plated fittings, 18 stainless steel wires

AS 12 1405 MB „Scandinavian Birch“

With its thin Vintage Maple shell, this Artist Snare Drum offers excellent resonance and a clear, transparent sound. The classic Scandinavian Birch finish and the 24k gold-plated fittings give it a very high end look. Its warm and rich sound make this snare drum quite versatile and naturally suited to a wide variety of musical styles.

Features: 9 ply Vintage Maple shell, 4 mm shell thickness plus 2 mm Dynamic Edges, 45° bearing edge, satin lacquer finish, single flange hoops, 20 tension rods, TuneSafe, Dual Glide snare action, 24k gold-plated fittings, 18 bronze wires

AS 12 1405 BG Brass Gold

The best choice for drummers looking for an explosive, bright sound with a high level of force and soft shading. Offering a broad sound with sensitive response for all playing dynamics, this snare drum also features 24k gold-plated fittings.

Features: Brass shell, 1 mm shell thickness, 45° bearing edge, protection lacquer, die-cast hoops, 20 tension rods, TuneSafe, Dual Glide snare action, 24k gold-plated fittings, 24 brass wires

AS 12 1406 BRB Bronze Black

The "heavyweight" of the Artist series, this snare drum is made of a 14" x 6" cast bronze shell. Similar to the cymbal making process, the shell is made of one piece of bronze for best resonance and full projection. Offering maximum volume, it is the ideal Drum for music requiring a sharp, loud and powerful snare.

Features: Bronze shell, 3 mm shell thickness plus 2 mm Dynamic Edges, protection lacquer, die-cast hoops, 20 tension rods, TuneSafe, Dual Glide snare action, black-plated fittings, 24 bronze wires

AS 12 1305 EA „Earth“

The main feature of this Artist Snare Drum is the massive, 27 ply (and hence 26 mm thick) beechwood shell; this gives the snare a 'hefty' sound. It is deep, with lots of 'bottom', and yet transparent. Well suited for funk, fusion, jungle or electronic beats. The 24k gold-plated fittings, combined with a lustrous lacquer finish, are a real show stopper.

Features: 27 ply Beech shell, 26 mm shell thickness, 45° bearing edge, high gloss lacquer finish, 16 tension rods, TuneSafe, Dual Glide snare action, 24k gold-plated fittings, 18 brass wires

AS 1406 CM „Cottonwood“

Perfect as an all-round snare drum this model features a 9 ply maple medium shell, a unique Cottonwood satin finish and die-cast chrome plated hoops. Producing a warm and full tone with a harmonic frequency, it also offers very clear attack and sensitive response due to the stainless steel wires.

Features: 9 ply Medium Maple shell, 6 mm shell thickness, 45° bearing edge, satin lacquer finish, die-cast hoops, 20 tension rods, TuneSafe, Dual Glide snare action, chrome plated fittings, 24 stainless steel wires

AS 12 1405 SB Steel Black

The heart of this Artist Snare Drum is a chrome-plated stainless steel shell. The perfect studio snare drum, it's also well suited to rock and funk drummers. Excellent rim shot sounds, a rich tone and a broad spectrum of medium-range and high pitches are other distinguishing features. The shell is equipped with black-plated hoops and fittings.

Features: Steel shell, 1 mm shell thickness, 45° bearing edge, protection lacquer, 20 tension rods, TuneSafe, Dual Glide snare action, black-plated fittings, 2 x 8 stainless steel wires

AS 12 1307 AM „Amboina“

The latest addition to the Artist Snare programme is the highly select 13" x 7" Amboina Snare. Constructed using a Heavy Maple shell, this snare drum embodies true perfection, only found in SONOR's superb quality construction. The sound ranges from sensitive moments to brute force – characterizing this all-around instrument with soft, warm tone in the lower pitches along with balanced mediums and highs. Using one of the finest burl wood veneers (Amboina) combined with 24k gold-plated fittings, this snare drum's look is breathtaking.

Features: 12 ply Heavy Maple shell, 8 mm shell thickness, 45° bearing edge, high gloss lacquer finish, 16 tension rods, TuneSafe, Dual Glide snare action, 24k gold-plated fittings, 18 brass wires





In late 2011, SONOR and Gavin began working on the "Protean" project with the goal to create a snare drum that is as musically versatile as Gavin himself. The name "Protean" comes from Greek mythology meaning "versatile" and "diverse". Gavin wanted this snare drum to be a daily workhorse instrument that can be quickly altered to suit the musical situation.

Construction and Finish

The Signature Snare is handcrafted in Germany and will be offered in two sizes, 14" x 5.25" and 12" x 5". They are made from 6-ply, 6 mm, hand-selected Birch featuring a timeless Silky Black finish which is offset by white underlays between the chrome fittings and the shell.

Hybrid Bearing Edges

The Snare reintroduces the vintage round bearing edge on top which SONOR last produced in 1975. On the bottom a modern 45 degree bearing edge is featured.

Hybrid Hoops

The Snares feature S-Hoops on the top side, and a special open, triple-flanged steel hoop on the bottom.

Vintage Lugs

Gavin's choice of lugs are the vintage Phonic lugs to add "mass" to the shell while eliminating stress from high tension.

Dual Glide System

Gavin loved the benefits of the new Dual Glide Snare System, but took the idea a little further. The open bottom hoop makes the Dual Glide strainer even more versatile, as multiple snare wires can be used and exchanged quickly. Tuning the bottom head with the snares off is much easier.

Unique Dampening Rings

Another special feature is a set of three newly designed dampening rings that are available in different widths (Light, Medium and Heavy dampening). Any range of overtone dampening can be achieved by using them separately or combined.

New Protean Tuning Keys

As a touring Pro, Gavin has to tune and exchange heads on a regular basis. Over the years he developed his own technique, which led to the development of a set of two special designed tuning keys. The Protean keys make the exchange of heads and tuning, easier, faster and more convenient.



Signature Snare Drums Gavin Harrison

„Protean“ available models:
SSD 13 1205 GH Standard Edition
SSD 13 14x5,25 GH Standard Edition
SSD 13 1205 GH Premium Edition
SSD 13 14x5,25 GH Premium Edition



„Protean is the best of vintage meets modern innovation and to play it is my dream come true.“
GAVIN HARRISON

Benny Greb

Since 2004, drumming scene's shooting star Benny Greb is part of the SONOR family. Says Benny: "For me as an artist it is key to embrace both tradition and innovation, and the guys at the Sonor Drum company do that same thing. I feel close to people that love what they do and who are dedicated to quality. That's why I feel close to the Sonor Company." Benny can be found playing with an assortment of musicians, all demanding his tasteful and immaculate playing style. Early 2010, SONOR and Benny begun working on a very special Snare Drum, Benny's very own Signature model that is as versatile and musical as Benny himself. Benny favors Beech, and that's what gives the Drum its transparency, warmth and a wide tuning range with a fat sound. The beautiful outer veneer is Scandinavian Birch that adds a timeless look to the Drum. But it wouldn't be Benny without adding something very special. The personalized Benny Greb badge shows his unique "Cartoon-head", and a synthetic design ring is being applied to the shell.



"In all of my recent recordings you can hear the huge sound and versatility of this great instrument. I'm happy to share this sound now with you. Have fun with it!"
Benny Greb

Signature Snare Drum Benny Greb (SSD 10 13x5.75 BG)

13" x 5.75" Signature Snare Drum, Scandinavian Birch, satin lacquered finish, equipped with a specially designed Benny Greb badge and synthetic design ring, 9 ply Thin Beech shell, 5 mm shell thickness, 45° bearing edge, Artist series lugs with TuneSafe, 16 tension rods, 2.3 mm Power Hoops, throw-off snare action, chrome-plated shell



Mikkey Dee

Mikkey, best known as the Drum-Powerhouse for Rock'n Roll's loudest live-band: Motörhead, has been part of the SONOR family of artists for more than 30 years. After filling the drum throne for artists such as King Diamond & Dokken and having appeared on numerous recordings, Mikkey joined Motörhead in the early 90's. His style, both unique and powerful is recognized as the key ingredient to Motörhead's thunderous sound! The 14" x 7.25" Snare Drum features Mikkey's favorite shell construction, a 6 ply Birch shell. A shell that is known for its wide tuning range, powerful mids and highs, and well balanced low end. A thrilling artwork by Motörhead's album designer Mark Devito features some of Rock's most popular icons and perfects the latest addition to SONOR's growing Signature Snare Drum line.



"This is the actual size I've been playing all these years with SONOR. It delivers a well balanced tone and is loud enough to catch up with Motörhead. Check it out, you will love it."
Mikkey Dee

Signature Snare Drum Mikkey Dee (SSD 12 14x7.25 MD)

14" x 7.25" Signature Snare Drum, 6 ply Birch shell, 7.2 mm shell thickness, 45° bearing edge, chrome shell hardware, unique Motörhead wrap design by Mark Devito, SONOR design tuning lugs with TuneSafe, 20 tension rods, throw-off snare action, 2.3 mm Power Hoops, Signature series badge, equipped with REMO drumheads, 20 steel wires



Phil Rudd

With over 30 years of deep relationship, SONOR and Phil Rudd teamed up to create a unique and exclusive Signature Snare Drum model. The Snare Drum is based on Phil's all-time favourite Snare Drum, the SONOR Horst Link Signature Brass model, while adding exciting new features and face. The final prototype Snare Drum was presented to Phil in early 2009 during the "Black Ice" World Tour and used from thereon.



"I'm always looking for a fat intimidating sound that's punchy with an edge on it"
Phil Rudd > AC/DC

Signature Snare Drum Phil Rudd (SSD 11 1405 PR)

14" x 5" Signature Snare Drum, Chrome over Brass, equipped with a signed Re-Issue of the 1980's Signature badge, Brass shell, 1.2 mm shell thickness, 45° bearing edge, Artist series die-cast hoops, 20 tension rods, TuneSafe, throw-off snare action, chrome-plated shell hardware, 20 steel wires

Steve Smith

Steve Smith, one of the world's greatest drummers, has been endorsing SONOR Drums for more than 30 years. Steve and the SONOR engineers created a true masterpiece that is addicted to sound, features, design and most of all, Steve's input. The 14" x 5.5" Signature Snare Drum is an outstanding instrument, made out of an exclusive, 2.5 mm cast steel shell / 2.5 mm reinforcement rings and two air vents.

Vintage style Phonic lugs with integrated TuneSafe are in place for a vintage look, and die-cast hoops and a REMO fiberskyn 3 batter head in Diplomat thickness add to the overall effect of what Steve is looking for in a snare drum: a crisp, full-bodied instrument with an immediate and effortless playing response.

Besides the Signature badge, Steve's Signature is engraved on a Re-Issue of the "Hilite Exclusive" badge, adding another "Vintage SONOR" touch.



"SONOR drums have remained my first and only choice as a high quality instrument for the past 30 years. My sound is the 'SONOR sound', I can't imagine playing any other drum kit"
Steve Smith

Signature Snare Drum Steve Smith (SSD 11 1455 STS)

14" x 5.5" Signature Snare Drum, Chrome, equipped with a signed Re-Issue of the 1988's Hilite Exclusive badge, cast steel shell, 2.5 mm shell thickness with 2.5 mm reinforcement rings, 45° bearing edge, Phonic series Re-Issue tuning lugs with TuneSafe, 20 tension slotted rods, REMO Fiberskyn 3 Diplomat batter head, Artist series die-cast hoops, 2 hidden ventholes, throw-off snare action, chrome-plated shell hardware, SONOR SoundWire with 24 stainless steel wires

the
re-issue
OF THE FAMOUS PHONIC SNARE DRUM

Steve Smith



Phonic Re-Issue Snare Drum Mahogany (D 516 MR)

14" x 6.5" Re-Issue Snare Drum, 9 ply Beech shell, 8.5 mm shell thickness, 45° bearing edge, Mahogany outer and Beech inner veneer, chrome shell hardware, Phonic double lugs, 20 slotted tension rods, die-cast hoops, throw-off snare action, vintage Phonic series badge, REMO USA drumheads Throw-Off Snare Action Phonic snare drums feature the SONOR throw-off snare action.



Phonic Re-Issue Snare Drum Rosewood (D 515 PA)

14" x 5.75" Re-Issue Snare Drum, 12 ply Beech shell, 10.5 mm shell thickness, 45° bearing edge, Rosewood outer and inner veneer, chrome shell hardware, Phonic double lugs, 20 slotted tension rods, die-cast hoops, throw-off snare action, vintage Phonic series badge, REMO USA drumheads



SONOR Museum

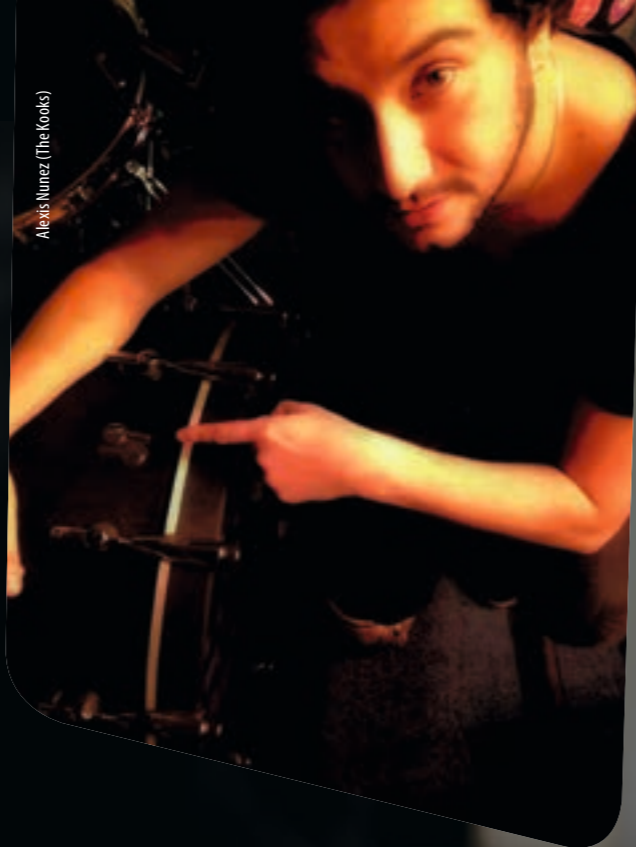

Alexis Nunez (The Kooks)

The „Duplex“ from 1927



a history of its own

Whereas drums and percussion instruments have been used to create rhythm patterns from the most simple all the way to the most complex for centuries now, bass drum pedals are quite a young phenomenon in comparison. Their own evolution begun when the modern drum set kicked off.

SONOR has been one of the first companies in drum history to manufacture pedals and is still on top of the game. From the early days with very simple mechanism dating back to the beginning of the last century to technically perfected pedals today: countless innovations were developed over decades.



The „Perfect Balance“ from 2012

SonorMuseum.de



PERFECT BALANCE BY JOJO MAYER

The main philosophy behind this pedal is to achieve perfect harmony and interplay between the pedal's moving parts and your foot. Due to careful design and perfectly balanced linear action any non-vital adjustments are obsolete and omitted on purpose. Other than the pedal's folding and mounting mechanism, all adjustments such as spring tension, footboard height and beater angle are classic, industry standard solutions.

„The Perfect Balance Pedal is a carefully calibrated system that optimizes the linear translation of your foot movements and makes many adjustments expendable. It was designed with a principle in mind that reflects ultimate sophistication to me:

Simplicity.

Essentially, it could be described as the soul and feel of a vintage pedal reincarnated in the technology of a 21st century body.“

Jojo Mayer

Jojo Mayer



Self mounting clamp



Push button for folding



Spring hold by a magnet



Perfect Balance Pedal
Bass Drum Single Pedal, with ballistic fiber strap, self mounting clamp, push button for folding, spring hold by a magnet, pedal bag

Low Mass Drive System

The drive cam and beater hub are streamlined into a single unit for low mass and carefully calibrated for perfectly balanced strokes. Round cam design creates linear acceleration which is a major advantage for many hybrid techniques.

Elongated Board

Elongated and smooth footboard adds more leverage to the stroke and allows extended range of movement for heel toe and sliding techniques.

Self Mounting Clamp

Quick mounts the pedal with a single motion. Clamp adjusts to all hoop thicknesses.

Ballistic Fiber Strap

Ballistic fiber strap minimizes inertia of the drive system and offers a quicker and smoother response than chain or solid drives.

Folding Mechanism

Folds the pedal into compact size for easy transportation with the push of a button. For extended lifespan, the spring can be dislocated and secured with a magnet when folded.



GIANT STEP

Maximum Speed and Power

SONOR Giant Step bass drum pedals are the best tool for discriminating drummers refusing to sacrifice any musical freedom. As a state-of-the-art pedal, Giant Step delivers an optimum feel for the music along with speed and handling. The extraordinary design and numerous enhancement options elevate Giant Step pedals to a class unto themselves. From the Target Point foot board to the docking station, every aspect of the Giant Step series has been designed with the utmost attention to detail.



GSP 3 Single Pedal
Target Point, Rotation Pendulum, Smart Connect and Docking Station¹.

Docking Station¹ Smart Connect System – The Flexible Pedal Attachment

The "Smart Connect" system means quick and effortless attachment of the pedal with an adjustable ball clamp through a firm lever mechanism. A cylindrical axle connection neutralizes any possible tensions traditionally caused by different bass drum angle positions.

Anti Slip Rubber – Get a grip on any surface!

The bass drum plate has an anti-slip rubber profile with self-adhesive velcro.



Docking Station



Giant Step Bag



GDPR 3 Double Pedal

This double pedal effectively demonstrates the modular system of the Giant Step series. Separate modules of the Single pedal make up the double pedal, featuring extremely smooth action. The connecting axle is length adjustable, and the high quality cross joints are covered by rubber housings.



¹) US pat. 6.632.990
EU pat. 1.237.146

Did you know?

The first SONOR pedal dates back to the year 1900! It is on display in the SONOR museum at the company's headquarter in Germany.



600 Series PEDALS

600 series

- Bass drum pedal utilizing Giant Step design
- Smooth, fast pedal action due to unique SONOR construction
- Smart Connect System with Docking Station for quick and reliable bass drum mounting
- Two way beater for choice of attack sound
- Adjustable toe stop



SP 673

Bass Drum Single Pedal, with bag, Smart Connect System, Docking Station, two way beater, adjustable toe stop

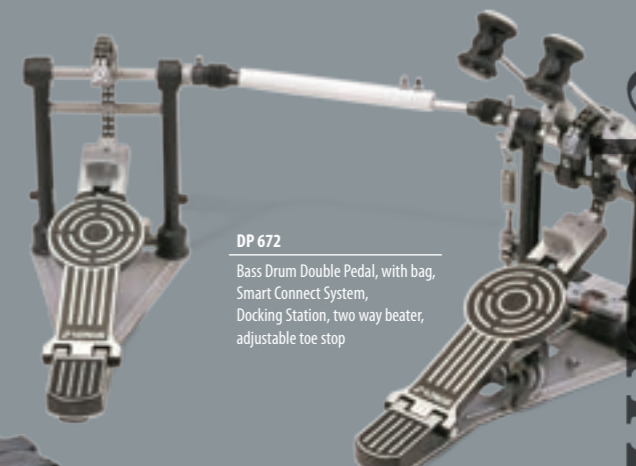

DP 672

Bass Drum Double Pedal, with bag, Smart Connect System, Docking Station, two way beater, adjustable toe stop



Pedal Bag



Docking Station



SP 473

Bass Drum Single Pedal, with support board and adjustable toe stop



Pedal Bag

400 Series PEDALS



DP 472 L

Bass Drum Double Pedal, left, with bag, with support board, adjustable toe stop, for left-footed players



DP 472 R

Bass Drum Double Pedal, right, with bag, with support board, adjustable toe stop

Sonor Museum.de

600 Hardware Series

The pinnacle of SONOR hardware. Offering maximum reliability and optimum handling with lots of individual components. Professional down to the smallest detail! The 3-section clamp diffuses the force around three sides of a stand rod like no other clamp does! Plus, it can be secured easily. The independently adjustable base leg of the hardware 600 suits each drummer's individual set-up. Completely retractable cymbal boom arm converts the mini boom stand to a straight cymbal stand.

4000 Hardware Series

Professional, road-ready hardware at an unbeatable price. Equipped with lots of individual components, the 4000 Series is easy to set up, adjust and tear down. Completely retractable cymbal boom arm converts the mini boom stand to a straight cymbal stand

2000 Hardware Series

SONOR's basic hardware series is characterized by good handling with professional appearance. The hardware standard with lots of grip for added playing confidence.



Hi-Hat Stands

600 Hardware Hi-Hat Stands

HH 674 MC Hi-Hat Stand (see HH 684)
HH 684 MC Two-Leg Hi-Hat Stand, with adjustable spring tension, swivel foot board, retractable, with toe stop, 7-step bottom cymbal tilter, legs convertible from rubber to metal spurs

400 Hardware Hi-Hat Stand

HH 400 Hi-Hat Stand with adjustable spring tension, swivel foot board, retractable, with toe stop, 7-step bottom cymbal tilter

200 Hardware Hi-Hat Stands

HH 200 Hi-Hat Stand with swivel footboard
HH XS 200 Hi-Hat Stand, extra low, adjustable height range: 650 mm - 820 mm



**Bottom Cymbal Tilter Secure-Fastening
Massive and Flexible**

7-step, easy to operate cymbal tilter



Drum Thrones

6000 Hardware Drum Thrones

DT 6000 RT Drummer's Throne, round seat, with spindle, with Drum Key Holder, adjustable height range: 460 mm - 660 mm
DT 6000 ST Drummer's Throne, saddle seat, with spindle, with Drum Key Holder, adjustable height range: 460 mm - 660 mm

4000 Hardware Drum Thrones

DT 4000 Drummer's Throne, round seat, with spindle, with Drum Key Holder, adjustable height range: 460 mm - 620 mm

2000 Hardware Drum Thrones

DT 2000 Drummer's Throne, round seat, extractable tube, with Drum Key Holder, adjustable height range: 440 mm - 600 mm
DT XS 2000 Drummer's Throne, extra low, adjustable height range: 390 mm - 560 mm

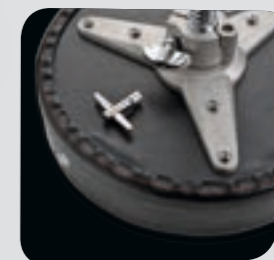

Drum Key Holder

The search for a drum key is history: with the innovative SONOR drum key holder you can always find your key right under the throne top.

DT 6000 RT Round Top / DT 6000 ST Saddle Top

- New 2-segment top / tube clamp
- New tuning key holder included
- Spindle drive
- Reinforced brace connection
- New round and saddle throne tops with improved comfort padding and shape
- New rubber foot design



SonorMuseum.de

Derrick Frost (Chiodos)

Cymbal Stands

600 Hardware Cymbal Stands

- CBS 672 MC** Cymbal Boom Stand, 400 mm boom arm length, 360° rotation
- MBS 673 MC** Mini Boom Stand with retractable boom arm, 485 mm boom arm length

4000 Hardware Cymbal Stands

- MBS 4000** Mini Boom Stand with retractable boom arm, 285 mm boom arm length

2000 Hardware Cymbal Stands

- MBS 2000** Mini Boom Stand, 285 mm boom arm length
- MBS LT 2000** Mini Boom Stand, single braced
- MBS 53** Mini Boom Stand, 285 mm boom arm length

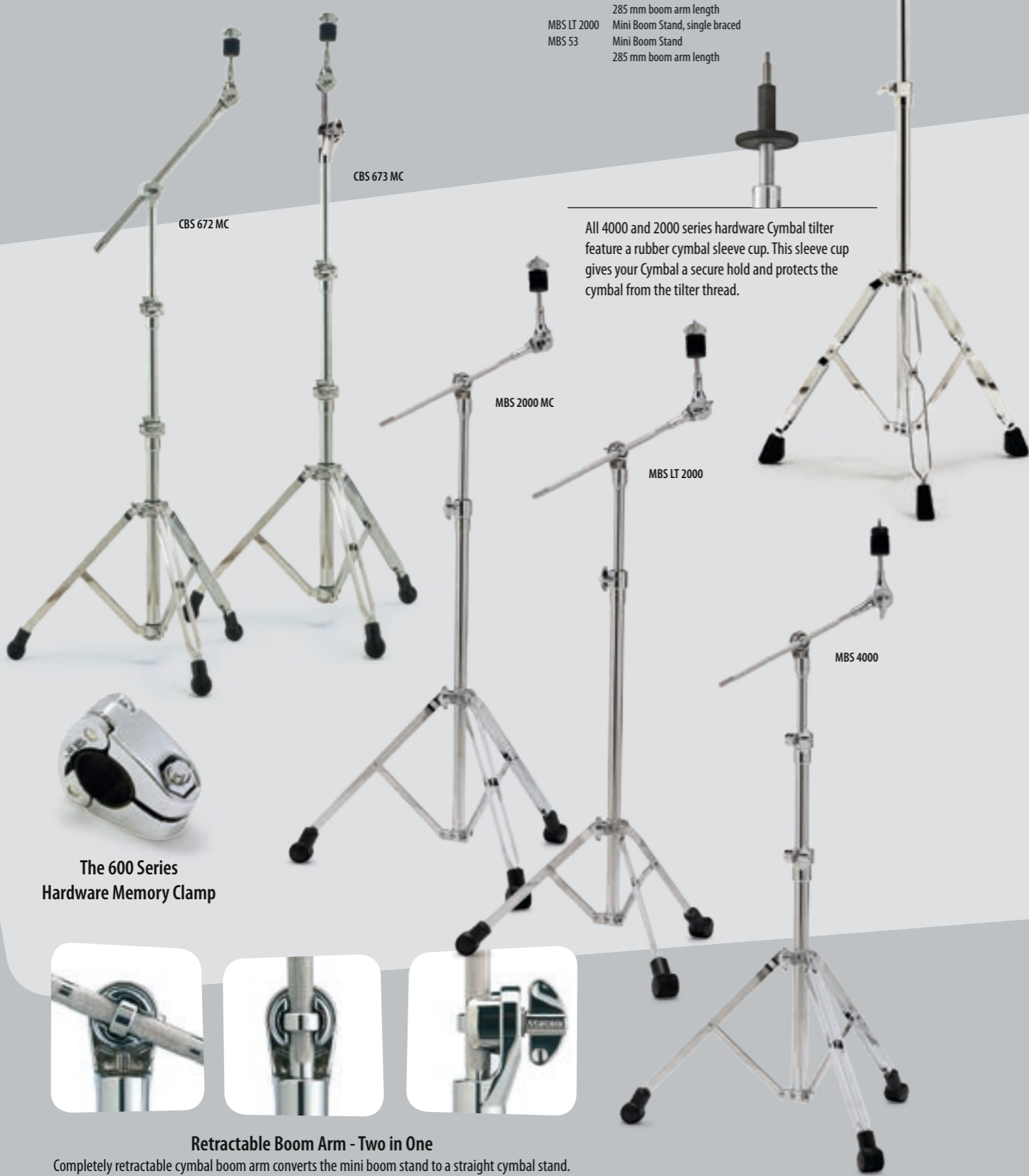

All 4000 and 2000 series hardware Cymbal tilter feature a rubber cymbal sleeve cup. This sleeve cup gives your Cymbal a secure hold and protects the cymbal from the tilter thread.



The 600 Series Hardware Memory Clamp



Retractable Boom Arm - Two in One

Completely retractable cymbal boom arm converts the mini boom stand to a straight cymbal stand.

Double Cymbal Stands

600 Hardware Cymbal Stands

- DCS 678 MC** Double Cymbal Stand with two cymbal boom arms

4000 Hardware Cymbal Stands

- DCS 4000** Double Cymbal Stand with two cymbal boom arms



The new cymbal tilter on 4000 series stands can be infinitely adjusted to any angle.

The new lever screw adjusts the tilter and applies more torque than a traditional wing screw to ensure a rock solid setting. The lever can be moved independently after the tilter is set, leaving the cymbal unobstructed.



All 4000 cymbal stands/ holders feature our new locking, 8mm quick-release wingnut that will ensure a quick setup and teardown of your cymbals.

3-Section Clamp¹

The 3-section clamp diffuses the force around three sides of a stand rod like no other clamp does! Plus, it can be secured easily.



New 4000 Series 2-Segment Memory Clamp

Cymbal Boom Arms

600 Hardware Cymbal Arm

- CBA 671 MC** Cymbal Boom Arm, 400 mm boom arm length, 360° rotation

600 Hardware Mini Boom Arm

- MBA 4000** Mini Boom Arm, 285 mm boom arm length



Did you know?

The legs of all our hardware 600 and 6000 stands are equipped with solid stainless steel rivets. Build to last: we take it serious. That's why we offer a Lifetime Warranty on all solid stainless steel rivets.

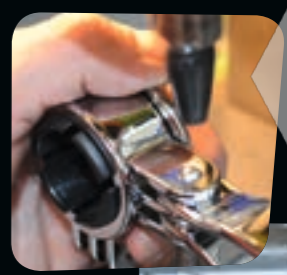

¹⁾ DE pat. 1023 57 515

Snare Stands

600 Hardware Snare Stands

SS 677 MC Snare Drum Stand with quick release lever, adjustable height range: 490 mm - 730 mm

4000 Hardware Snare Stands

SS 4000 Snare Drum Stand with toothless snare basket adjustment, adjustable height range: 490 mm - 660 mm

2000 Hardware Snare Stands

SS 2000 Snare Drum Stand, adjustable height range: 470 mm - 640 mm
 SS XS 2000 Snare Drum Stand, extra low, adjustable height range: 380 mm - 540 mm
 SS LT 2000 Snare Drum Stand, single braced, adjustable height range: 470 mm - 640 mm



SS 677 MC



SS 4000



Quick Release Lever - Couldn't Be Easier!

No more complicated screws ever again! Simply lay the snare drum on the stand and flip the lever - that's it.



The new rubber foot design enhances stability and ground contact of the stands.



SS 2000



SS LT 2000



SS XS 2000

Combination Stands

600 Hardware Combination Stand

CTS 679 MC Cymbal Tom Stand with tom arm with ball clamp² and cymbal boom arm

4000 Hardware Combination Stand

CTS 4000 Cymbal Tom Stand with tom arm with ball clamp² and cymbal boom arm



3) DE pat. 44 00 151 / JP pat. 2 564 110 / US pat. 5 509.629

Adjustable Leg - Fits Every Configuration³
 The independently adjustable base leg of the hardware 600 suits each drummer's individual set-up.



CTS 4000

CTS 679 MC

2) DE pat. 43 33 913 / GB pat. 2 273 043 / US pat. 5 848.642

Tom Stands

600 Hardware Tom Stands

DTS 675 MC Double Tom Stand, 2 tom arms with ball clamp²
 STS 676 MC Single Tom Stand with tom arm with ball clamp²

4000 Hardware Tom Stands

DTS 4000 Double Tom Stand, 2 tom arms with ball clamp²
 STS 4000 Single Tom Stand with tom arm with ball clamp²



DTS 675 MC

DTS 676 MC

DTS 4000

STS 4000

the Basic Arm System

Freedom, Flexibility & Function

The Basic Arm System allows you to create your own customized individual hardware setup. The Basic Arm System is divided into the Basic Arm 19 and Basic Arm 12, reflecting the variation in tube diameters. We utilize identical ratchets overall for ease of compatibility between the components. The details are too many to mention – experiment and design the Basic Arm System of your own.



BA-BC, BA19-BR, BA19-S, BA19-BR, BA19-M, BA-TA



BA-BC, BA19-BR, BA19-S, BA19-BR, BA19-M, BA-BC



BA19-BSS, BA19-S, BA-TA



BA19-BSS, BA19-S, BA19-BR, BA19-S, BA-TA



BA-BC, BA-CR, BA12-BR (3x), BA12-L, BA-CH, BA-PA



BA12, BA12-BR (5x), BA-CH (3x), BA-PA (2x)



BA-BC, BA19-BR, BA19-M, BA-BC



CBS 672 Cymbal Boom Stand with BA-BC, BA-CR, BA12-BR, BA12-L, BA12-BR (2x), BA-MA (2x)

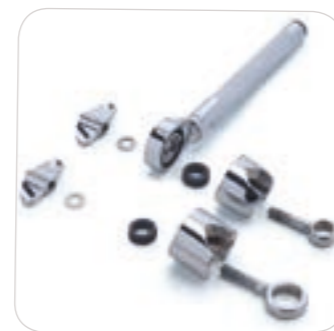

Simply combine and assemble your Basic Arm components.



Easy and clever: Depending on the combination of your Basic Arm components simply remove a gide ring.



BA19-BDS MC

BA19-BSS MC



BA19-BDA, BA-CR, BA19-BR, BA19-M, BA-BC



BA19-BDA, BA19-S, BA19-BR, BA-PA

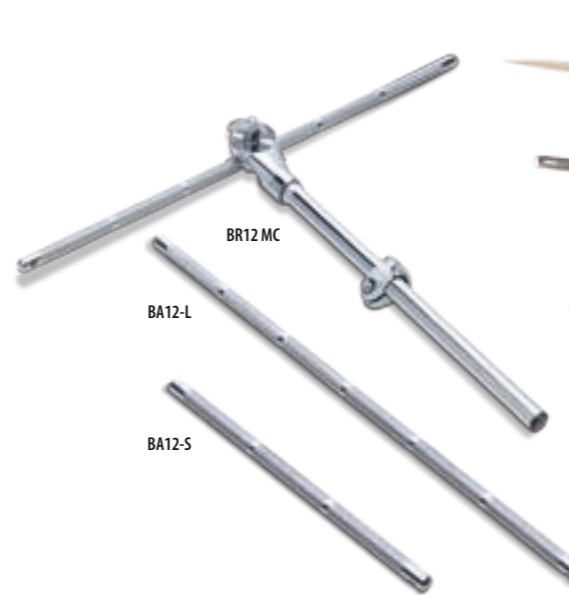

BR12 MC

BA12-L

BA12-S

Basic Arm 19

- BA19-S MC Basic Arm 19, short, 150 mm
- BA19-M MC Basic Arm 19, medium, 220 mm
- BA19-L MC Basic Arm 19, long, 400 mm
- BA19-BR Basic Arm 19 Basic Ratchet
- BA19-BDA Basic Arm 19 Bass Drum Adapter
- BA19-BSS MC Basic Arm 19 Single Stand
- BA19-BDS MC Basic Arm 19 Double Stand



BA-CH

BA-PA

BA-TA

BA-MA

BA-CR

BA-BC

BA19-S MC

BA19-M MC

BA19-L MC

BA-TB

BA12-BR

BA19-BR

Basic Arm 12

- R12-MC Basic Rack, with Arm 485 mm
- BA12-S Basic Arm 12, short, 285 mm
- BA12-L Basic Arm 12, long, 485 mm
- BA12-BR Basic Arm 12 Basic Ratchet

Basic System

- BA-CH Basic Arm Cymbal Holder
- BA-PA Basic Arm Percussion Adapter
- BA-TA Basic Arm Tom Adapter
- BA-BC Basic Arm Basic Clamp
- BA-CR Basic Arm Connection Ratchet
- BA-TB Basic Arm Tele Boom, 550 mm
- BA-MA Basic Arm Microphone Adapter



BA19-BDA

SonorMuseum.de



Tom Holder

62 | 63 **HARDWARE**

600 Hardware Tom Holders

- DTH 675MC Double Tom Holder with 2 tom arms with ball clamp²
- STH 674 MC Single Tom Holder with 3-section clamp and tom arm with ball clamp²
- TA 678 MC Tom Arm with ball clamp²



DTH 675MC

STH 674 MC

TA 678 MC

4000 Hardware Tom Holders

- DTH 4000 Double Tom Holder with 2 tom arms with ball clamp²
- DTH 4000 BC Double Tom Holder black chrome
- DTH 4000 BP Double Tom Holder black powder
- STH 4000 Single Tom Holder with 2-section clamp and tom arm with ball clamp²
- STH 4000 BC Single Tom Holder black chrome
- STH 4000 BP Single Tom Holder black powder
- TA 4000 Tom Arm with ball clamp²
- TA 4000 BC Tom Arm black chrome
- TA 4000 BP Tom Arm black powder

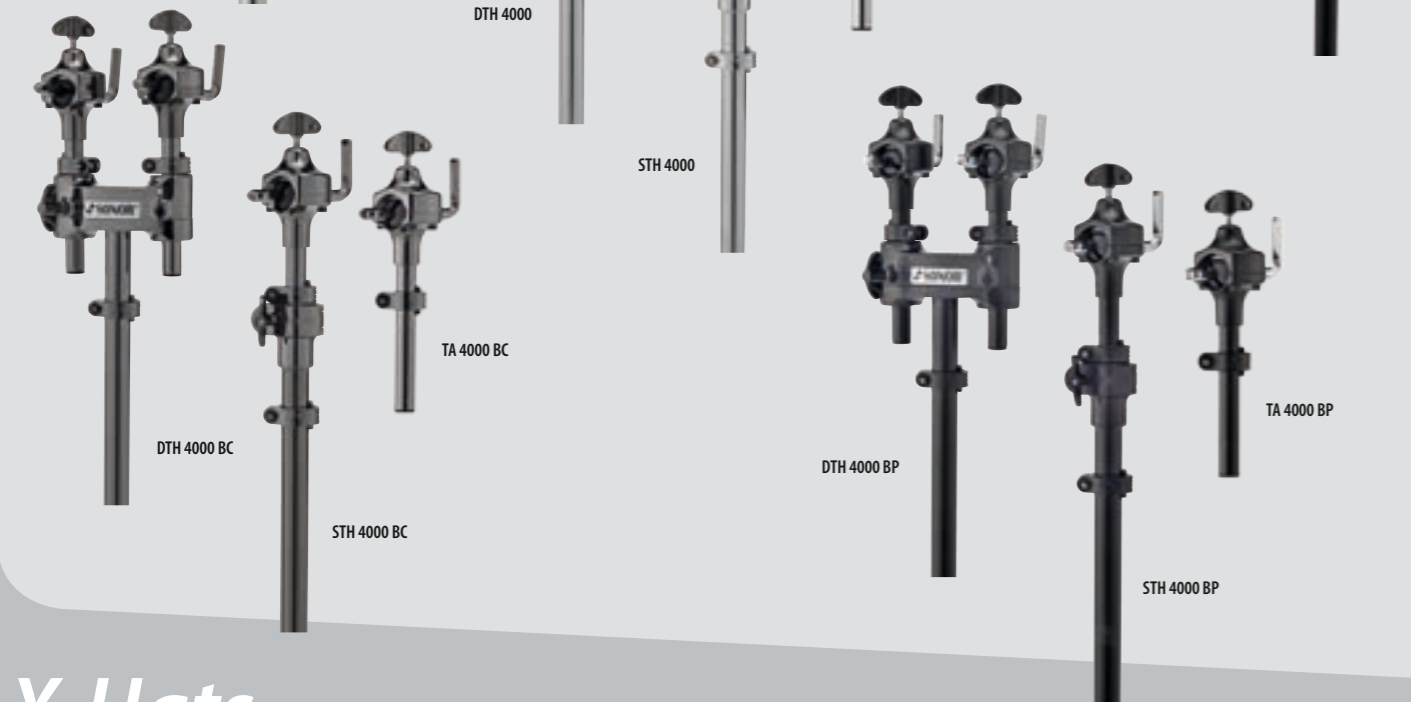

DTH 4000

STH 4000

TA 4000

DTH 2000

DTH 2000 BP

TA 4000 BC

DTH 4000 BC

STH 4000 BC

DTH 4000 BP

TA 4000 BP

STH 4000 BP

2000 Hardware Tom Holders

- DTH 2000 Double Tom Holder with ball clamp²
- DTH 2000 BP Double Tom Holder black powder

Hardware Sets

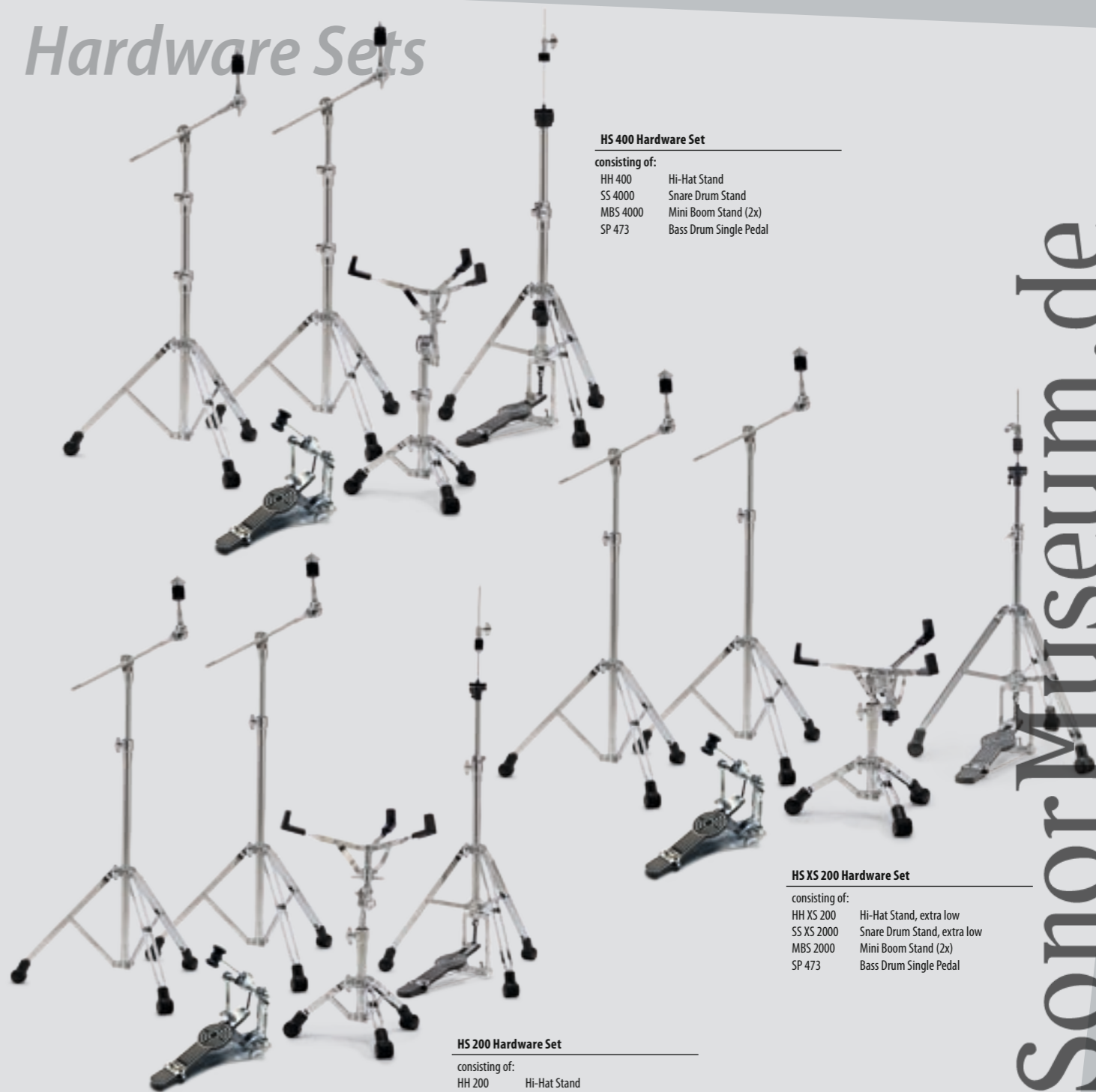

HS 400 Hardware Set

- consisting of:
- HH 400 Hi-Hat Stand
 - SS 4000 Snare Drum Stand
 - MBS 4000 Mini Boom Stand (2x)
 - SP 473 Bass Drum Single Pedal

HS XS 200 Hardware Set

- consisting of:
- HH XS 200 Hi-Hat Stand, extra low
 - SS XS 2000 Snare Drum Stand, extra low
 - MBS 2000 Mini Boom Stand (2x)
 - SP 473 Bass Drum Single Pedal

HS 200 Hardware Set

- consisting of:
- HH 200 Hi-Hat Stand
 - SS 2000 Snare Drum Stand
 - MBS 2000 Mini Boom Stand (2x)
 - SP 473 Bass Drum Single Pedal

X-Hats

600 Hardware X-Hat

- XH 674 X-Hat with adjustable spring tension, 7-step bottom cymbal tilter



400 Hardware X-Hat

- XH 474 X-Hat with adjustable spring tension, 7-step bottom cymbal tilter

Multi Holder

400 Hardware Multi Holder

- MH 475 Multi Holder for X-Hat



²) DE pat. 43 33 913 / GB pat. 2.273 043 / US pat. 5.803.642

Multi Clamps

600 Hardware Multi Clamp

- MC 676 Multi Clamp



400 Hardware Multi Clamp

- MC 276 Multi Clamp



Accessories

Often, it's the little things that make the difference. SONOR Accessories cover all of the important and useful accessories and replacement parts you'll ever need.

SONOR Accessories

- CC 5215 Cymbal Clamp, plastic, single unit
- CC 5215/6 Cymbal Clamp, plastic, six pack
- PP 9300 Practice Pad for 14" Snare Drum, rubber
- SL 5205 Super Lock Tuning Safe Set, 20 pieces
- BDE 16"/18" Bass Drum Elevation with spurs extension, Prism Clamp with drilling template, Jungle adapter

Bass Drum Beaters

- SCH 20 Bass Drum felt beater with conical shape
- SCH 28 Two Way Beater, with two playing surfaces: felt and plastic

Memory Locks

- ML-R for Bass Drum spur right
- ML-L for Bass Drum spur left
- ML-VT for Vintage Series Bass Drum spurs and Tom Tom mounts

Tuning Keys

- PTK „Protean“ Tuning Key (square head rods)
- RK Rotor Key incl. Lanyard clip and key ring (square head rods / slotted rods as from the year 2006)
- MTK Multi Tuning Key (square/Allen head rods SW 4)
- DK 5070 Wrench Key (slotted rods)
- DK 5072 Tuning Key, short (slotted rods)
- DK 5073 Tuning Key (square head rods)

3-Section Memory Clamps

with plastic inlay to protect the tube surface available for
19.1 mm tube diameter
25.4 mm tube diameter
28.5 mm tube diameter

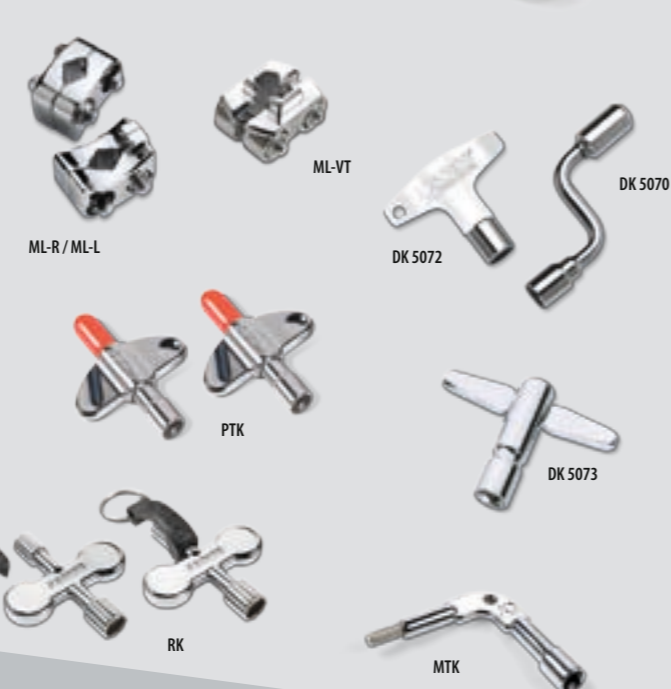

Soundwires

High quality snare wires made in Germany

SoundWire is SONOR's answer to any drummer looking for new ways to enhance their snare drum sound. With 3 different materials (steel, brass and bronze) and multiple snare wire variations plus the mounting options of string or strap, SoundWire offers almost unlimited sonic choices.

SONOR SoundWire snares feature specially designed end plates that ensure perfect snares-to-head contact. Rounded plate edges prevent head damage during snare tightening. Each set of snares comes in an attractive wood box that ensures best protection.



Steel Snare Wires

- SW 1218 S for 12", 18 Wires ø 0.5 mm
- SW 1318 S for 13", 18 Wires ø 0.5 mm
- SW 1418 S for 14", 18 Wires ø 0.5 mm
- SW 1424 S for 14", 24 Wires ø 0.5 mm

Bronze Snare Wires

- SW 1018 B for 10", 18 Wires ø 0.5 mm
- SW 1418 B for 14", 18 Wires ø 0.5 mm
- SW 1424 B for 14", 24 Wires ø 0.5 mm

Brass Snare Wires

- SW 1418 MS 05 for 14", 18 Wires ø 0.5 mm
- SW 1424 MS 05 for 14", 24 Wires ø 0.5 mm

Dual Glide Snare Strainer Mechanism

The strainer mechanism features a technically perfected snare wire engage-and-release system, along with great adjustability and a solid look and feel. "DUAL GLIDE SYSTEM" refers to the precise and smooth action, which in turn eliminates any un-wanted sounds when the snare wires are placed in "on" or "off" position. Both the strainer and butt sides are equipped with a fast-release snare wire detach function, allowing the drummer to change the resonant head without having to loosen and adjust the Snare wires. A fine-tune adjustment knob is employed on both sides.

Thanks to the well thought-out design and construction, the new Dual Glide strainer also works to replace the current strainer on most of SONOR's snare drums, and is available as an individual component.

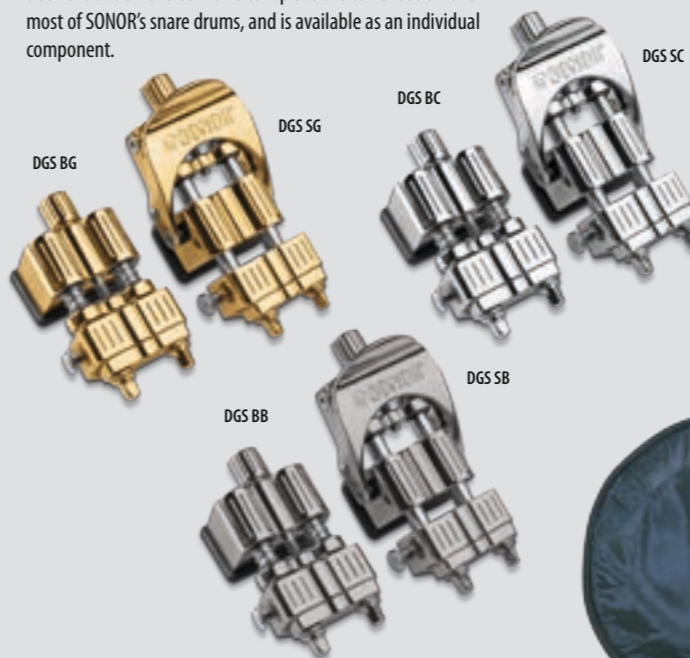

Dual Glide Snare Strainer

- DGS SC Dual Glide Snare Strainer, chrome-plated, single unit
- DGS BC Dual Glide Butt End, chrome-plated, single unit
- DGS SB Dual Glide Snare Strainer, black-plated, single unit
- DGS BB Dual Glide Butt End, black-plated, single unit
- DGS SG Dual Glide Snare Strainer, gold-plated, single unit
- DGS BG Dual Glide Butt End, gold-plated, single unit

Bags

Global Bags for Snare Drums

- GB S 1405 Bag for a 14" x 5.5" Snare Drum
- GB S 1406 Bag for a 14" x 6.5" Snare Drum

Global Bag for Cymbals

- GB C 22 Bag for Cymbals up to 22"

SONOR Stick Bag

- SSB Stick Bag, professional version



GB S 1405 / GB S 1406

Drumheads

Power Black - Front Head/SONOR Logo

- Edge ring, black, single ply, medium
- PB 18 B/L = 18"
- PB 20 B/L = 20"
- PB 22 B/L = 22"
- PB 24 B/L = 24"
- PW 24 B/L = 24"

Power White - Front Head/SONOR Logo

- Edge ring, white, coated, single ply, medium
- PW 18 B/L = 18"
- PW 20 B/L = 20"
- PW 22 B/L = 22"
- PW 24 B/L = 24"

Drumsticks

Z 5642 Hickory Drumsticks

- 5A Oval shaped tip, all around stick, length: 40.9 cm / ø 14.3 mm
- 7A Oval shaped tip, longer than conventional 7A, sticks, for jazz etc., length: 40.3 cm / ø 13.5 mm
- 5B Oval shaped tip, for rock, marching, (ideal for rudiments), length: 41.2 cm / ø 15.5 mm
- ROCK Oval shaped tip, for rock etc., length: 41.2 cm / ø 14.3 mm
- FUNK Small round shaped tip, for funk, jazz, studio, length: 40.6 cm / ø 14.7 mm

Z 5643 Hickory Nylon Tip Drumsticks

- 5AN Nylon tip, shape as 5A model, length: 41.2 cm / ø 14.3 mm
- 7AN Nylon tip, shape as 7A model, length: 40.6 cm / ø 13.5 mm
- 5BN Nylon tip, shape as 5B model, length: 41.2 cm / ø 15.5 mm

SONOR Brushes

- Z 5720 Metal Brushes, retractable, rubber grip
- Z 5730 Rute Brushes, when sticks are too loud and regular brushes too soft, with more attack than brushes



SSB

Z 5720

Z 5730

SONOR MUSEUM

All hand-hammered Armoni Cymbals, made exclusively for SONOR by a traditional Turkish Cymbal company, are of B20 Bronze (a mix of 80% Copper and 20% Tin). The total production process is comprised of traditional handcrafted methods.



After melting and tempering the B20 Bronze, the material is rolled into discs and multiple pressed as the raw cymbal afterwards. Then the cymbals are hand hammered, lathed and polished.

Armoni Sounds

Our Armoni Cymbals deliver fast, lightening-bright sounds and modern response for today's musical styles. Every drummer looking for new and modern Cymbals will find the perfect sound in our Cymbal line.



AC SET 1 Armoni Cymbal Set 1
AC 14 HH 14" Hi-Hat Cymbal, brilliant
AC 16 C 16" Crash Cymbal, brilliant
AC 20 R 20" Ride Cymbal, brilliant
incl. Cymbal Bag

Armoni Series Cymbals
AC 13 HH 13" Hi-Hat Cymbal, brilliant
AC 14 HH 14" Hi-Hat Cymbal, brilliant
AC 14 C 14" Crash Cymbal, brilliant
AC 15 C 15" Crash Cymbal, brilliant
AC 16 C 16" Crash Cymbal, brilliant
AC 17 C 17" Crash Cymbal, brilliant
AC 18 C 18" Crash Cymbal, brilliant
AC 19 C 19" Crash Cymbal, brilliant
AC 20 R 20" Ride Cymbal, brilliant
AC 22 R 22" Ride Cymbal, brilliant
AC 08 S 8" Splash Cymbal, brilliant
AC 10 S 10" Splash Cymbal, brilliant
AC 12 S 12" Splash Cymbal, brilliant
AC 14 CH 14" China Cymbal, brilliant
AC 16 CH 16" China Cymbal, brilliant
AC 18 CH 18" China Cymbal, brilliant

The SQ² Drum System represents SONOR's extensive know-how in drum making and sound design. Building upon 140 years of manufacturing experience this range of custom instruments offers the ultimate in SONOR craftsmanship. It is the flagship within the SONOR drum program.

SQ² DRUM SYSTEM

As a leading manufacturer of highest quality drums and percussion instruments SONOR has always set new standards and opened doors to new levels of perfection. The SONOR Signature series, first introduced in the mid 80's is one example. Later the SONOR Designer series introduced true custom design to the drumming community. Now with SQ² SONOR again demonstrates its innovative power and uncompromising dedication to quality.

SQ² is more than a drum series. It is a concept both of making drums and selecting drums. With an almost unlimited variety of shell- size-finish combinations, SQ² is the most individualized series in SONOR's history, offering the most unique drums you have ever dreamed of playing. It allows you to speak with your personal musical voice. It is your signature in sound.

Start building your dream here:

sq2-drumsystem.com

sonor.com

Jared Shavelson (Boys&stir)

be unique

II SonorMuseum.de

