



**SONOR**

1875 - 1975



... für Schlagzeuger  
... for Drummers  
... pour Batteurs

Museum.de





First SONOR factory



Founder Johannes Link



Consul Otto Link



Horst Link (Pres.)



Jörg Link

SONOR factory today



## 100 Years – 4 Link Generations

Johannes Link, the founder of SONOR, was born in 1847 in the small Bavarian village of Forheim, near Nördlingen. As a young man he travelled as a journeyman wood turner to Weissenfels on the Saale River, where in 1875 he began making military drums and drum skins. Tympani and other percussion instruments were added gradually to cover the entire range of percussion instruments. By the turn of the century SONOR had attained a world-wide reputation. The SONOR trademark, first registered with the Imperial Patents Office in 1907, is recognized as a symbol of quality everywhere.

After the death of the founder in 1914, his son Otto Link assumed management of the firm, and extended the enterprise by acquiring a sawmill and establishing a wholesale branch in Markneukirchen. Under the direction of Otto Link, later to become Hon. Consul of Sweden, the firm was led with success through wars, inflation, depression, and expropriation by the German Democratic Republik. In 1950, Otto and his son Horst, combined with several loyal and experienced employees, built a new modern and efficient plant in Aue (Westphalia).

Consul Link died in 1955, and Horst became manager. Under his direction SONOR combines modern techniques and machinery to produce a complete range of percussion instruments, outstanding in design and quality. The greatgrand son of the founder, Jörg Link, who has an M. S. in Economics, now assists in the management of the company.

Today SONOR is a leader in its field, exporting more than half of its total production to almost every major country in the world. SONOR's management is dedicated to the principles of teamwork and cooperation, and remains alert to all social and technological changes that will allow it to take free advantage of the most modern techniques wherever necessary. Management also realizes that without the full support and loyal cooperation of its dedicated and loyal employees, SONOR would not enjoy the international success it is so proud of today.



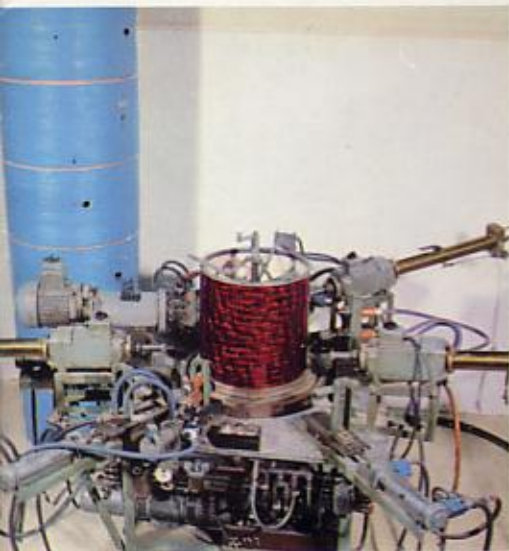
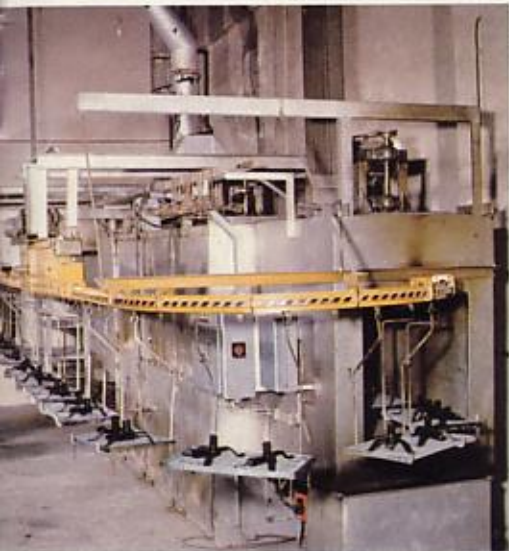
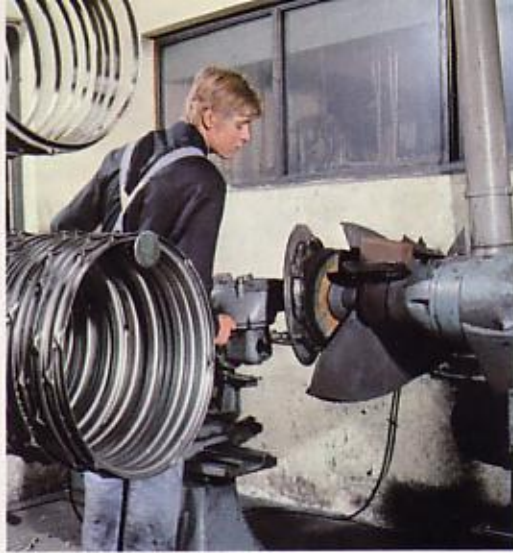
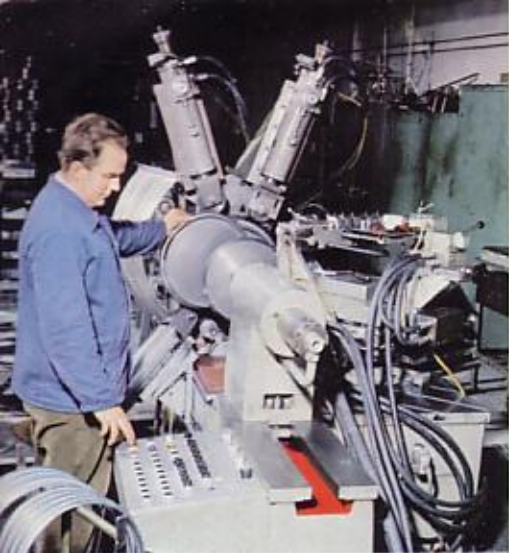

**From the SONOR factory:**

- A projecting machine is used for drawing seamless metal shells and profile hoops.
- An automated process is used for baking on a mar proof and scratch resistant lacquer finish.
- An automatic precision drilling machine ensures perfect alignment of all fittings.

- An automatic polishing machine is used for treating the metal surfaces before plating.
- Modern woodworking machines guarantee precise tolerances and labor saving operations.
- During assembly a final check is made of all the individual parts, which come from various departments of the factory.

- All metal parts are copper-plated, nickel-plated and chrome-plated.
- The full vibrating sound shells are formed in special oil-heated presses.
- Containers being loaded from our modern shipping facilities for world-wide distribution.

[www.sonor-museum.de](http://www.sonor-museum.de)





4-point vertical tension, adjustable from either side, allows snares to lay perfectly flat on the head for sharp response.

Extra attachment for Hi-Hat (patented) allows for smooth adjustment of spring tension to compensate for size and weight of cymbals.



### K 100 KS Double Bass Drum Set "Super Champion"

- G 241 2 Bass Drums 22" x 14"
- D 555 Snare Drum 14" x 5"
- T 649 Tom-Tom 12" x 8" with muffler and tom-tom holder
- T 650 Tom-Tom 13" x 9" with muffler and tom-tom holder
- T 652 Tom-Tom 16" x 16" with muffler and legs
- T 653 Tom-Tom 18" x 16" with muffler and legs
- Z 5321 2 Drum Pedals "Super Champion"
- Z 5553 Drum Stand "Champion"
- Z 5453 Hi-Hat "Champion" with special holder to attach to bass drum
- Z 5459 Extra Attachment for Hi-Hat (patented) for smooth adjustable spring tension
- Z 52222 2 Cymbal Stands "Champion" with tilters
- Z 5056 2 Drum Anchors
- Z 5602 Drum Sticks

Available substitute:  
2 Bass Drums G 242 (24" dia.) instead of G 241 (22" dia.)

All instruments are equipped with genuine Remo Heads.



SonorMuseum.de





SonorMuseum.de





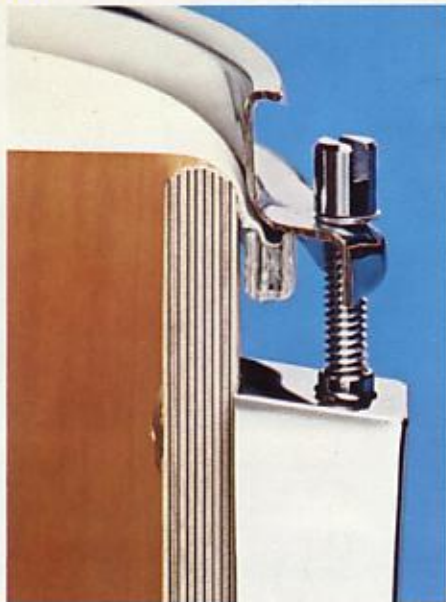
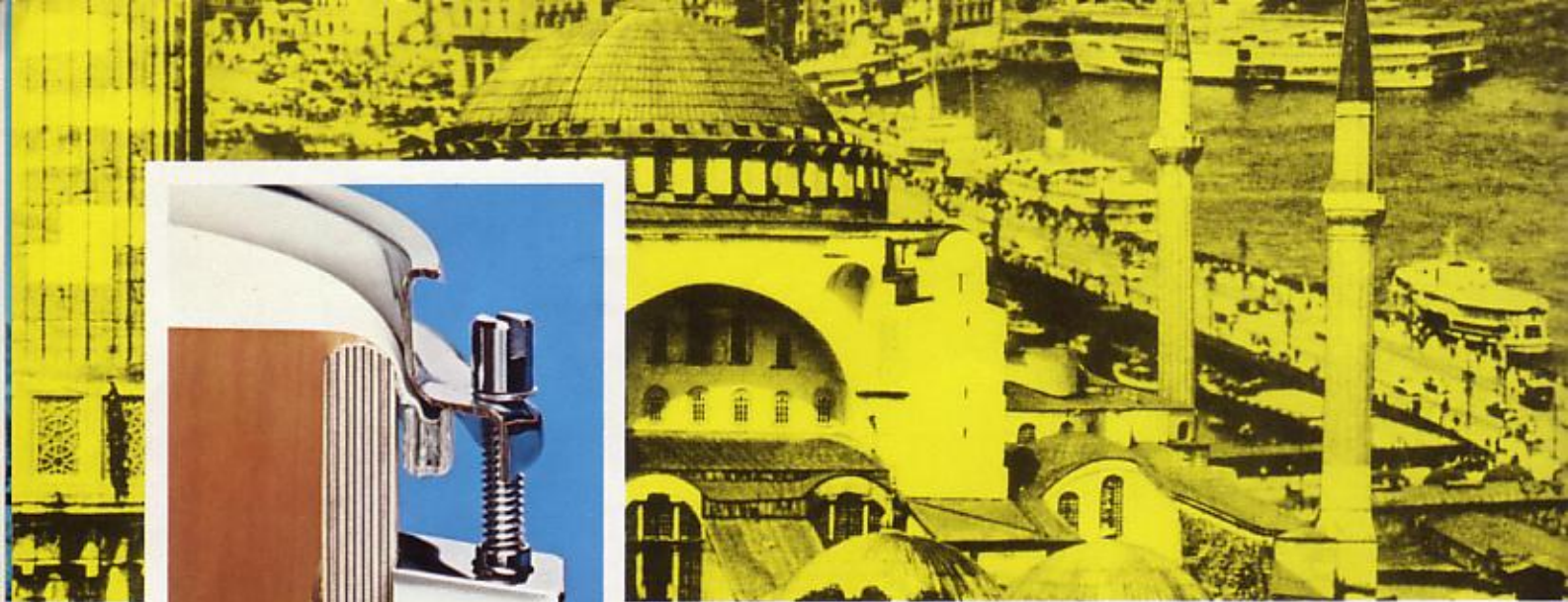

"Full vibrating sound shells" are guaranteed by floating heads, and by exclusive heat molded process which requires no sound-deadening reinforcements.

Two dimensional adjustable spurs with prism clamping device (patented) convertible from rubber tip to metal spur.



**K 163 KO "Champion six"**

- G 262 Bass Drum 24" x 14"
- D 454 Snare Drum 14" x 5"
- T 660 Tom-Tom 13" x 9" with muffler
- T 658 Tom-Tom 14" x 10" with muffler
- Z 5503b Double Tom-Tom Holder
- T 662 Tom-Tom 16" x 16" with muffler and legs
- T 663 Tom-Tom 18" x 16" with muffler and legs
- Z 5319 Drum Pedal "Champion"
- Z 5553 Drum Stand "Champion"
- Z 5452 Hi-Hat "Champion"
- Z 5222 2 Cymbal Stands "Champion" with tilters
- Z 5602 Drum Sticks

Available substitute: Snare Drum D 555, as illustrated, instead of D 454.

All instruments are equipped with genuine Remo Heads.



SonorMuseum.de



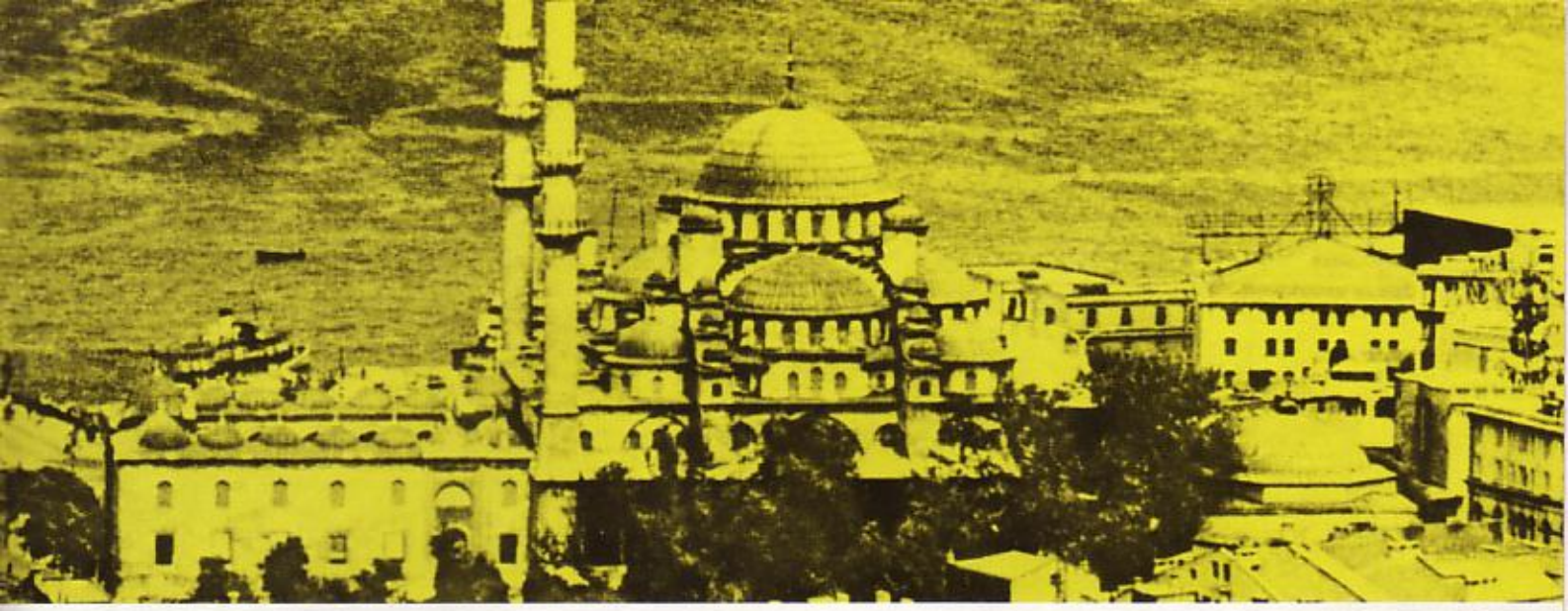

SONOR

Champion

SonorMuseum.de





SonorMuseum.de



Available substitute:  
Tom-Tom Holder Z 5503 b,  
as illustrated, instead of Z 5504 d.

Tripod legs are convertible from  
rubber to metal tip, which ensures  
stability and prevents sliding.

#### K 162/04 KR "Champion five"

- G 261 Bass Drum 22" x 14"
- D 454 Snare Drum 14" x 5"
- T 659 Tom-Tom 12" x 8"  
with muffler
- T 660 Tom-Tom 13" x 9"  
with muffler
- Z 5504 d Double Tom-Tom Holder
- T 662 Tom-Tom 16" x 16"  
with muffler and legs
- Z 5319 Drum Pedal "Champion"
- Z 5553 Drum Stand "Champion"
- Z 5452 Hi-Hat "Champion"
- Z 5222 2 Cymbal Stands "Champion"  
with tilters
- Z 5602 Drum Sticks

All instruments are equipped with genuine  
Remo Heads.





PA



SR



SL



B

- PA rosewood
- SR red typhoon
- SL light grey
- B black
- SD glacier white
- KB metallic blue
- KO metallic orange
- KS metallic silver
- KR metallic red
- SB blue marble
- Bn blue stripe
- Un blue slate
- Tn red slate



KB

**Available colors from stock:**

- PA rosewood
- B black
- KB metallic blue
- KO metallic orange
- KS metallic silver
- KR metallic red

Other colors available on special order



KS



KR



SB



Bn



Un



Tn





Self-aligning, spring-loaded inserts allow fast and easy tensioning of the heads.

**D 555 Snare Drum 14" x 5"**  
 Seamless metal shell with center bead,  
 Seamless super profile counter hoops,  
 Remo Heads,  
 10 metal lugs with spring-loaded inserts,  
 20 tension rods with locking counter nuts,  
 Tone control,  
 Snare strainer with 4-point vertical tension, adjustable from either side,  
 All metal snares with 22 strands.



**D 426 Snare Drum 14" x 5"**  
 Seamless metal shell and  
 seamless super profile  
 counter hoops,  
 Remo Heads,  
 8 metal lugs, double tension,  
 with spring-loaded inserts,  
 Tone control,  
 Parallel action snare  
 mechanism with direct axle  
 control,  
 12 individually adjustable  
 snares.

**D 454 Snare Drum 14" x 5"**  
 Seamless metal shell with  
 center bead,  
 Seamless super profile  
 counter hoops,  
 Remo Heads,  
 8 metal lugs, double tension,  
 Tone control,  
 Snares with 20 strands and  
 4-point attachment.

**D 556 Snare Drum 14" x 6 1/2"**  
 Seamless metal shell with  
 center bead,  
 Seamless super profile  
 counter hoops,  
 Remo Heads,  
 10 metal lugs with spring-  
 loaded inserts,  
 20 tension rods with locking  
 counter nuts,  
 Tone control,  
 Snare stainer with 4-point  
 vertical tension, adjustable  
 from either side,  
 All metal snares with  
 22 strands.



4-point vertical tension,  
 adjustable from either side,  
 allows snares to lay perfectly  
 flat on the head for sharp  
 response.



SonorMuseum.de





## SONOR Drummers . . . all over the world

Biff Adam USA · Charly Antolini CH · Erich Bachträgl A · Peter Baumeister D · Fred Below Jr. USA  
Melvin Bevenue USA · Gerard van Bezey NL · Bob Blumenhoven D · Kurt Bong D  
Dai Bowen GB · Fred Braceful USA · Toni Braitner A · Chuck Brougham USA · Suzanne Buckley USA  
Kenneth Buttrey USA · Hugo Chambers USA · Jim Chapin USA · Buddy Charles USA  
Buck' Clarke USA · Claude Clemons USA · Stuff Combe CH · Ray Corriea USA · Eddie Coward USA  
Jack DeJohnette USA · Hans Dölle D · John Engels Jr. NL · Harold Fisher GB · Frank Gant USA  
Jörg Gebhardt D · Richie Goldberg GB · Tim Griffin USA · Paul Guerrero USA · Dick Hall USA  
Hans Harbrecht D · Joe Harris USA · Wayne Jernigan USA · Gilbey Karno ZA · Connie Kay USA  
Don Lamond USA · Robert Last D · Buddy Lowell USA · Ken Mairs USA · Kenny Malone USA  
Tommy Marken USA · Hank Marshall USA · Gary McDonald USA · Jim McGillivray GB  
Armand Molinetti F · Randy Mordini USA · Tom Moropoulos USA · Ray Mosca USA · Bob Moses USA  
Gegé Munari I · Fritz Ozmec A · Sonny Payne USA · Charles Perry USA · Garry Peterson USA  
Skip Prokop CDN · Pretty Purdie USA · Rolf Quenzel D · „Razz“ Rea USA · Ben Riley USA



Ron Roche USA · Buddy Rogers USA · James Sargent GB · Steve Schaeffer USA · Lothar Scharf D  
Benno Schilling D · Rudi Sehring D · Judy Stach USA · George Staley USA · Phil Stanger USA  
Janos Stefanski PL · Ronnie Stephenson GB · Art Taylor USA · John Verhas B · „Luigi“ Waites USA  
Rod Wells USA · Jerry Wiggins USA · Francois Zanotti CH  
Biff Adam USA · Charly Antolini CH · Erich Bachträgl A · Peter Baumeister D · Fred Below Jr. USA  
Melvin Bevenue USA · Gerard van Bezey NL · Bob Blumenhoven D · Kurt Bong D  
Dai Bowen GB · Fred Braceful USA · Toni Braitner A · Chuck Brougham USA · Suzanne Buckley USA  
Kenneth Buttrey USA · Hugo Chambers USA · Jim Chapin USA · Buddy Charles USA  
Buck' Clarke USA · Claude Clemons USA · Stuff Combe CH · Ray Corriea USA · Eddie Coward USA  
Jack DeJohnette USA · Hans Dölle D · John Engels Jr. NL · Harold Fisher GB · Frank Gant USA  
Jörg Gebhardt D · Richie Goldberg GB · Tim Griffin USA · Paul Guerrero USA · Dick Hall USA



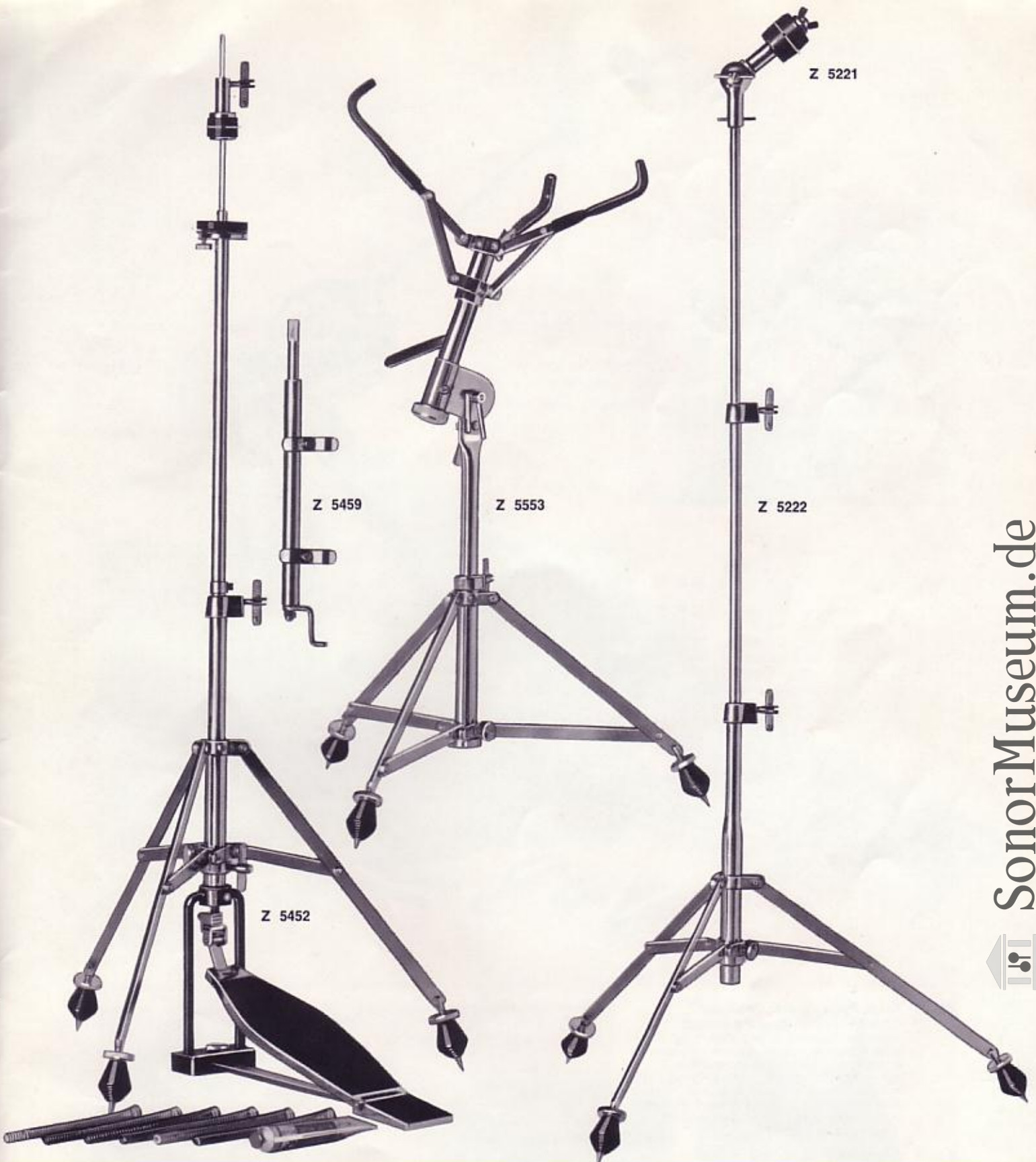

**Z 5452 Hi-Hat "Champion"**

Completely frictionless action through vertical pull of the foot board. Center base gives complete rigidity and allows uniform pressure of cymbals. Legs are convertible from rubber to metal spurs, insure stability and prevent sliding on any surface. Adjustable height. Hexed cymbal rod and top cymbal clutch nut. Provided with 6 interchangeable springs to adapt tension to weight of cymbals. Triple chrome plated.

**Z 5459 Hi-Hat Attachment (patented)**

Allows smooth adjustment of spring tension for every cymbal weight and type. Can be attached to any SONOR hi-hat.

**Z 5455 Hi-Hat "Super Champion" (patented)**

Same as hi-hat Z 5452, but with Z 5459 attachment assembled on hi-hat.

**Z 5553 Snare Drum Stand "Champion"**

Clamping arms require adjustment only once for the size of drum. A single lever locks or releases. Solidly constructed. Newly designed rest allows any desired position independent of ratchet system. Convertible rubber to metal spurs. Triple chrome plated.

**Z 5222 Cymbal Stand "Champion"**

Solid construction, suitable for the largest and heaviest cymbals. Telescopic adjustment. Convertible rubber to metal spurs. Tilter included. Triple chrome plated.

**Z 5221 Cymbal Tilter**

Adjustable fine ratchet link, with large machine knurled teeth. Fits all cymbal holders and stands. Triple chrome plated.



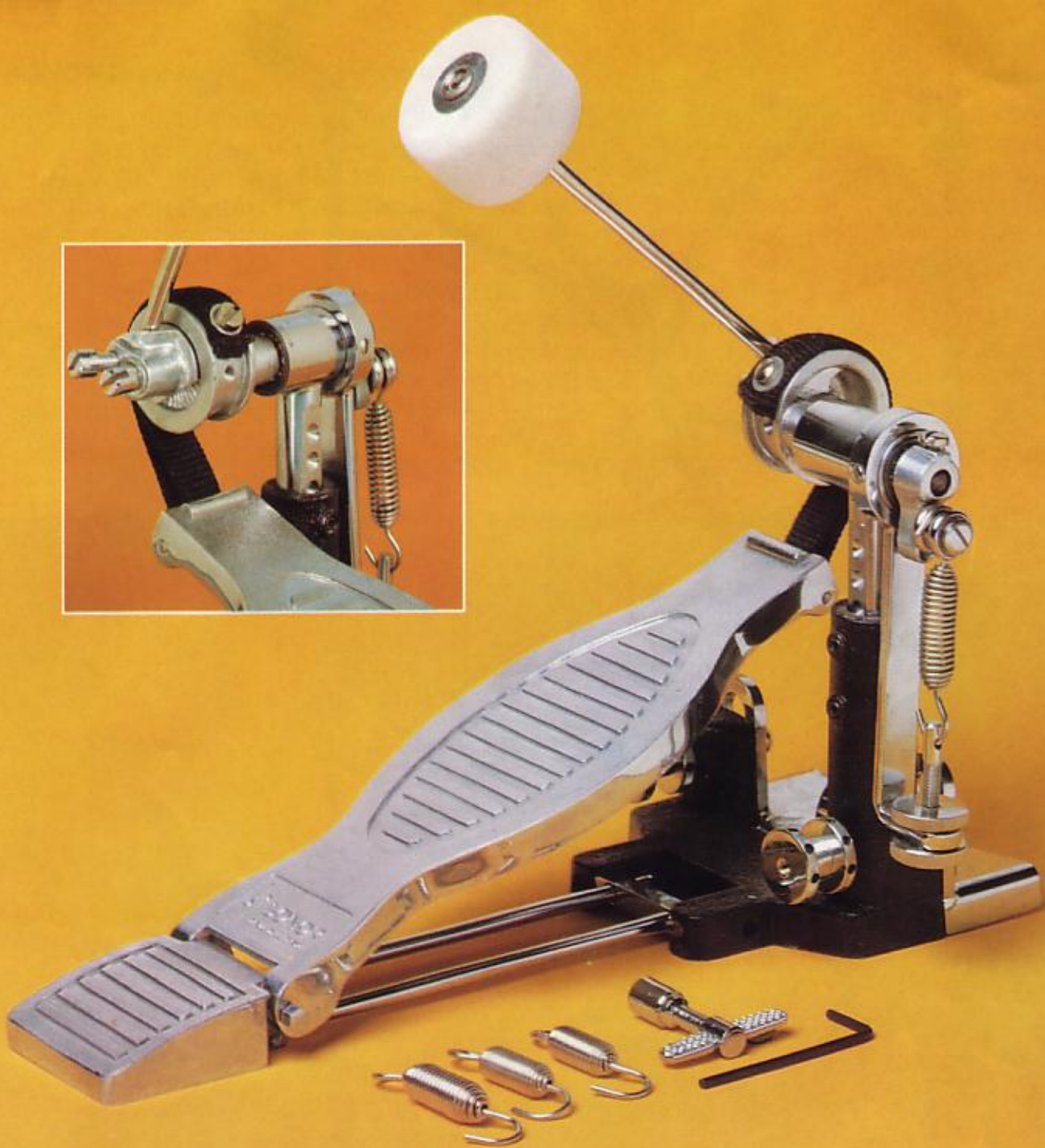

**Z 5321 Drum Pedal "Super Champion"**  
 Eccentric motion gives the greatest possible repeating speed. Fast, quiet needle-bearing action. Adjustable beater position and axle height. Adjustable spring tension. Newly designed large metal foot board with separate heel plate. Three extra springs of different tension provided. Attached to bass drum with bayonet joint. Triple chrome plated.

**Z 5319 Drum Pedal "Champion"**  
 Adjustable tension springs are invisibly fixed inside the twin posts. Eccentric motion gives the greatest possible repeating speed. Fast, quiet, twin ball bearing motion permanently lubricated. Special broad foot plate with separate heel. Wide clamp connection for bass drum. Triple chrome plated.

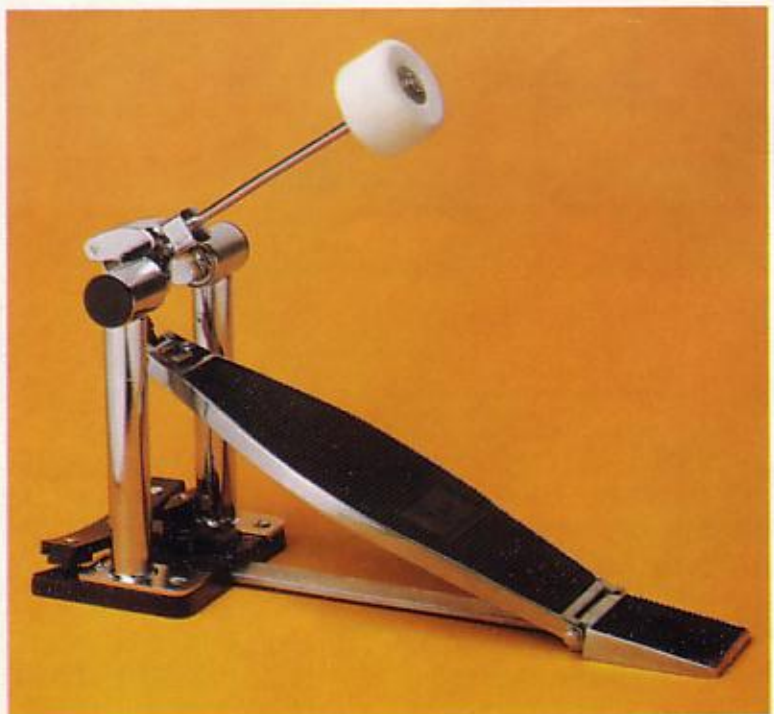



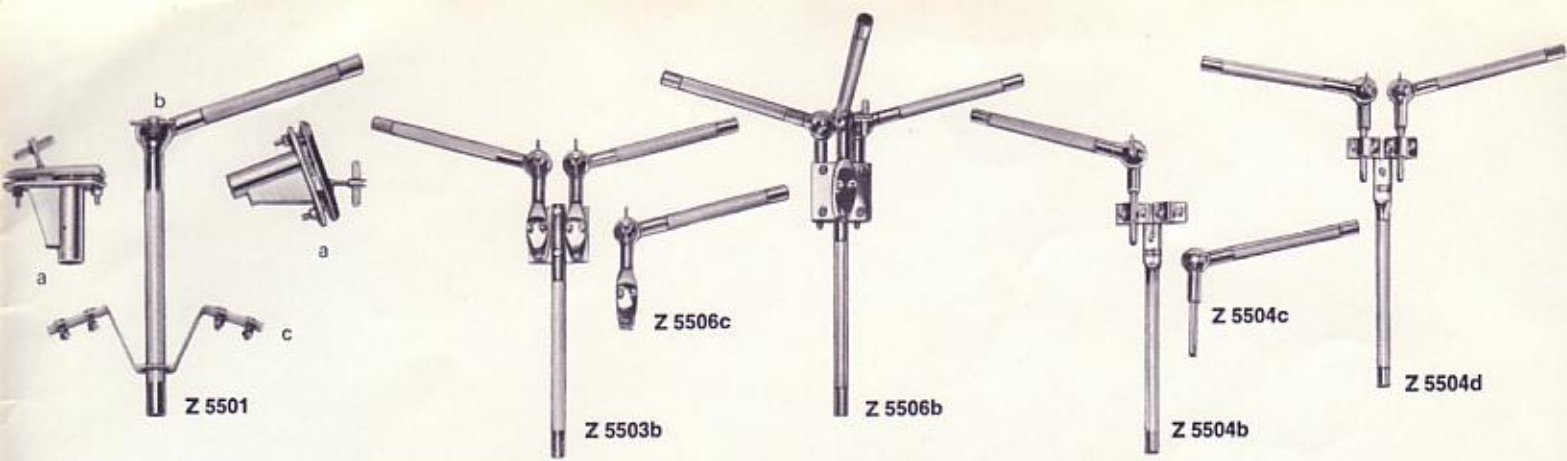

**Z 5501 Tom-Tom Holder**  
Complete, consisting of:  
2 shell mounts Z 5501a,  
1 ratchet link Z 5501b,  
1 steel support Z 5501c

**Z 5503b Double Tom-Tom Holder "Champion"**  
completely adjustable

**Z 5506c Supplementary arm with prism clamping device for triple tom-tom holder**

**Z 5506b Triple Tom-Tom Holder**  
completely adjustable

**Z 5504b Tom-Tom Holder "Swinger"**

**Z 5504c Supplementary arm for tom-tom holder "Swinger"**

**Z 5504d Double Tom-Tom Holder "Swinger"**  
completely adjustable

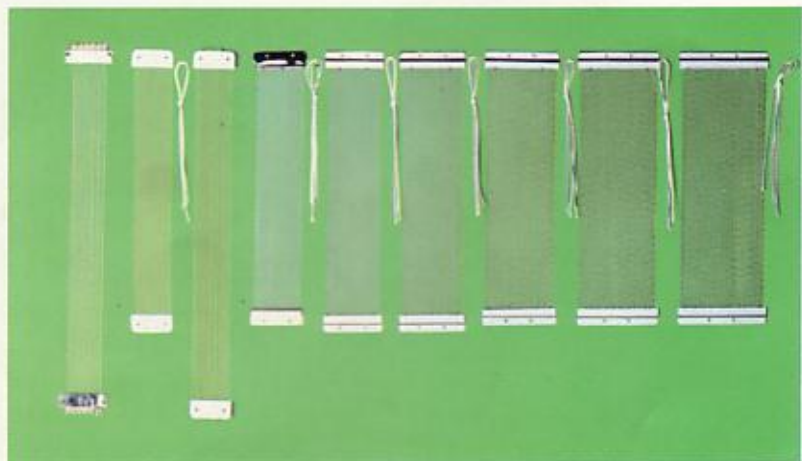

- Snares**
- 74 70 43** snares with 12 individually adjustable strands, for D 426
  - 74 70 21** snares with 18 strands
  - 74 70 31** snares with 18 strands, for D 426
  - 74 70 53** snares, all metal, 22 strands
  - 74 70 63** snares, all metal, 26 strands
  - 74 70 73** snares, all metal, 30 strands
  - 74 70 83** snares, all metal, 34 strands
  - 74 70 93** snares, all metal, 38 strands
  - 74 71 03** snares, all metal, 42 strands

**Drum Covers**  
Made of solid, first quality canvas, fabric-backed vinyl with strong zipper and handle  
for Bass Drums  
for Snare Drums  
for Tom-Toms







# SONOR

1875 - 1975



SonorMuseum.de



Exclusive USA Distributor:

**CHARLES ALDEN MUSIC CO., Inc.**

Southwest Industrial Park

Westwood, Mass. 02090

Phone (617) 326-6040

Catalogue 1743

© JOHS. LINK KG  
Printed in Germany